

To be original for us means to be leaning towards one's origin. Marble is our origin as well as being an extraordinarily unique material. The unique shape, the primordial nature, everything can always be traced back to its origin. We have followed the path of marble, mixing the contemporary modern with the history from which it descends, recent technology with the oldest tools, style with the rock that inspired it, design with the intrinsic light that this material possesses and is capable of diffusing in any ambience.







US



Welcome. This catalogue is meant to be a journey that shows who we are and where we come from, putting our products, our world, our history centre stage.

US. Claudia and Simone. Two siblings who have been running the family business since 2004. From our father Luciano we have inherited not only the company, but also the culture and the respect for work, the passion for what we do, and the desire to make this passion known beyond the confines of our beloved Tuscany. We come from a generation of marble workers. Our father started working marble when he was just a boy, and we too learnt words like marble and travertine early on, we gained experience in quarries and learnt about tools for quarrying and the subsequent processing.

Ours is a demanding job, in which fatigue, heat and cold are part of everyday life. But this is not a burden to us because our drive is made up of energy, of the desire to preserve the spirit of craftsmanship that we inherited from our father, the same spirit that we pass on to our children day after day. With the passing of time, the need grew within us to create a more exclusive, more defined, more contemporary product that would move away

from the deep-rooted idea of the 'heaviness' of the marble furnishing element, but that would be a beautiful design object regardless, where the marble, the material, could give a strong signal of added value. We therefore availed ourselves of the collaboration of experienced designers, who helped us not only to understand the market and its changes in relation to customer needs more directly, but also to be more aware of what we do and what we want to be. We have embarked on a path that starts from the individual marble table and stretches all the way to the complete furnishing of the living area, the place where every family meets, lives and interacts.

The collaboration with Maurizio Manzoni resulted in the Lenzi Home Collection. Lenzi is our brand, our name, simply US. Claudia and Simone Lenzi



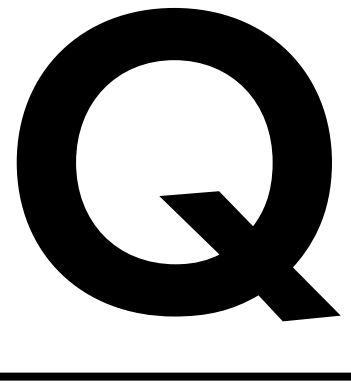

Q for Quarries. Italy, materials marble, travertine. The Company is located in the heart of Tuscany between Pisa and Florence. Italy, Tuscany, and our cities have always been seen as the cradle of art, with its masterpieces and monuments that enhance the beauty of the materials that the nature of our places gives us. From the mountains near Carrara, a Tuscan town an hour's drive from our company, we extract the famous Bianco Carrara, which takes its name from the town of origin. Carrara White is both a specific and a generic term. In the first case, this name refers to the white marble par excellence, a material with excellent qualities, which have made it known throughout the world and of which one can admire a shining example in the monuments that stand out in Piazza dei Miracoli in Pisa. But we also refer to Bianco di Carrara to define all the highly prized types of white that are extracted from the same mountains: Bianco Calacatta, Michelangelo, Statuario and others. Marble, like Roman Travertine, has always accompanied our history. This material as imperfect as it is unique that nature has lent us. Lenzi uses only first choice marbles and travertine selected directly by Simone Lenzi

in the best quarries. Marble is a unique and precious material that demands respect and we, thanks to the expertise we have acquired over the years, are able to work it skilfully.

Q for Quarries but also Q for Quality. Quality is what Lenzi guarantees for its products.

In our factory, we blend the long experience to shape this wonderful material with the contemporary design and our artisan skill to work this imperfect but handsome material the nature gives us.





C



C for Craftmanship Working with marble is not easy and requires in-depth knowledge of the characteristics of this precious material.

Like every material existing in nature, marble and travertine present themselves in all their imperfect beauty, in a state of matter that requires successive stages of selection and processing before it can shine with all its strength. There is a starting selection that requires profound experience to recognise what can be considered a defect and what should be considered a peculiarity of the material. It is precisely the peculiarity, the unique feature, that creates the material's singular beauty. The material itself is a mixture of dusts, sediments, dusts that have settled on the earth and crystallised over time, over millennia. And every single piece of material tells us what happened to the planet at that specific place on earth and at a time far in the past. That is why owning a marble product means owning a unique piece of nature's history.

The only one of its kind and represent a unique part of the human being heritage, millions of years in the making. The inherently imperfect nature of marble requires craftsmanship and an 'ad hoc' finish according to the specific natural characteristics of each piece. Therein lies the essence of our work, being able to adapt our extensive experience and knowledge to the care of the individual detail. The ability to work on a natural material to maximise its beauty and uniqueness. With passion.

Made in Italy. With care and love. For You.



M

The LENZI brand wanted to go beyond the approach of offering products interpreted as single moments and focus instead on a wide-ranging collection concept. The desire to create a collection in which each product was in a semantic correlation with the others was a fundamental cornerstone of the new course. A true total living project. To achieve this goal, the Lenzi siblings, Claudia and Simone, entrusted the architect Maurizio Manzoni with the Art Direction and development of the designs for the new course and the new concept, which started from an analysis of the brand's roots and remains traditionally known for its use of MARBLE as an essential material, and of contemporary living trends.

The LENZI HOME COLLECTION mood was born: a capsule collection developed with harmony and an innovative aesthetic taste. Every piece is a work of art, characterised by a sophisticated design, embellished with the most refined varieties of marble and finishes. The designed environment is delicate, elegant: the products are exalted by using high-end materials. The typical

peculiarities of the matter have been recovered from the company background and territory, then enhanced by artisanal workmanship of artistic elegance. This also represents the Made in Italy spirit, universally known and appreciated.

Maurizio Manzoni strove to exalt the primitive spirit inherent in matter. Elements such as stone and wood naturally shaped by the ages and from which the skilful hands of craftsmen have learnt over the centuries to take inspiration in their creations. Designing, then, is nothing other than showing how, thanks to the skilful and conscious use of the substances made available by nature, man can surround himself with products with which to enter into synergy. To propose a conciliatory environment, capable of placing the human being at the centre of his or her own private space. This is the LENZI commitment, which makes all this available to the needs of home living.

Maurizio Manzoni



I

TABLES

| | |
|---------|-----|
| ATENA | 16 |
| CLEPSY | 24 |
| CORALLO | 36 |
| ASTER | 46 |
| TOHO | 62 |
| ZEN 2.0 | 70 |
| ZEN | 80 |
| OASI | 88 |
| COSMOS | 98 |
| ORION | 106 |
| ECHO | 114 |
| LIAM | 124 |

CHAIRS

| | |
|----------|-----|
| CAMILA | 136 |
| MOVIE | 140 |
| BELT | 144 |
| IVY SLIM | 150 |
| IVY | 156 |

SOFAS

| | |
|-------|-----|
| CLAUS | 166 |
| HUG | 176 |
| ADON | 188 |
| ARIES | 196 |
| CLIFF | 204 |

ARMCHAIRS

| | |
|------|-----|
| IRIS | 214 |
| HUG | 222 |
| MAIA | 228 |

SIDEBOARDS

CABINET

CONSOLES

| | |
|---------|-----|
| LAYER | 238 |
| ALDER | 244 |
| CORE | 252 |
| HIRO | 266 |
| PILOTIS | 272 |
| VESTA | 276 |
| ASTER | 282 |
| FINN | 290 |

COFFEE TABLES

| | |
|--------|-----|
| EOS | 298 |
| ASTER | 302 |
| GLOW | 312 |
| NEBULA | 316 |
| CORO | 324 |
| GEMINI | 332 |

ACCESSORIES

| | |
|----------|-----|
| LOTO | 342 |
| SOLARE | 348 |
| STILETTO | 354 |
| MOON | 358 |
| ELIO | 362 |

T



Be original. Learning about origins by observing the present time through the lens of the past. And here is where we see a table which almost looks like a porthole overlooking sidereal space, even if its strong legs are like roots still planted on the Earth. A marble table. Black and all-encompassing, like the night of streaming lights of the metropolis. Or white and spiritual, like a daydreamed time travel. Or hybrid, like materials that envelop fragments of this precious material and highlight its visual effect.

T

ATENA



CLEPSY



CORALLO



ASTER



COSMOS



TOHO



ORION



ZEN



ECHO



OASI



LIAM



ATENA

Design Maurizio Manzoni

A temple inspired by past, present and future, the deity it houses and protects is in fact Time. Neat marble columns are reflected in a metal shield. Atena, in fact, explores a classical vision of balance and harmony, but contrasts it with a modern idea of strength and stability.









ATENA table. D/T 260CVLHC11. cm 260x118x76 h. Calacatta top and base elements. Metal trim on base and metal pedestal col. LHC11.
MOVIE chair. LC5. cm 49x49x73 h. Hard leather chair colour LC5.
PILOTIS console. 180ORLHC11. cm 180x48x84 h. Orobico marble top. Metal pedestals col. LHC11.
MOON mirror. 118RLC4. cm Ø 118x3. 80RLC4. cm Ø 80x3. Mirror composed by two mirror pieces and one Rosso Levanto inlay. Metal Frame colour LHC4.
STILETTO floor lamp. FLBN. cm 22x170 h. Floor lamp composed by a unique black metal structure and 3 different heights translucent marble columns.

CLEPSY

Design Maurizio Manzoni

Time and the art of men are the protagonists, with hours and days spent shaping the material, attending to the details of its form. Clepsy is a new hourglass, a medium in which time flows in two directions: the horizontal one, severe and rational, and the vertical one, made of passions and moods.











CLEPSY table. D/T BC/N1180. cm Ø 180x76 h. Veneered walnut top. Bianco Carrara solid pedestal.
MOVIE chair. LC5. cm 49x49x73 h. Hard leather chair colour LC5.
LOTO floor lamp. cm 28x150 h. Oyster marble, Bronze glass and chrome metal elements.



CORALLO

Design Maurizio Manzoni

It can express life, protection and beauty. Corallo is powerful, like any strong idea. But also as fascinating as an object sculpted by the movement of water in a seabed, as original as the style of multiform objects that only nature can create.











CORALLO table. D/T ORO260DK. cm 260x115x76 h. Orobico marble top and pedestals. Central metal frame col. Dark Shadow.
IVY chair. ARMILC1BC. cm 58x59x73 h. Hard leather armchair colour LC1. Front metal pedestal colour LHC5. Bianco Carrara details.
SOLARE wall lamp kit composed by: SOLARE A-1. Smoked glass element Ø 35 cm. SOLARE A-2. Smoked glass element Ø 42 cm. SOLARE A-3. Marble element Ø 30 cm

ASTER

Design Maurizio Manzoni

A dream of real vividness. Aster saturates the ambience with new, unknown sensations, and, in turn, it takes light from the room, to return it stronger. As with every star, intelligence and sensitivity are inherent in its nature.



ASTER table. D/T1160RLTR. cm Ø 160x76 h. Rosso levanto top. Gloss lacquered wooden cylinder colour Tuscany Red. Metal details colour LHC4.
CAMILA chair. LO01/1 RTM. cm 50x60x79 h. Chair covered with Bouclé fabric LO01/1. Metal structure colour Tuscany Red.





ASTER table. D/T1160RLTR. cm Ø 160x76 h. Rosso levanto top. Gloss lacquered wooden cylinder colour Tuscany Red. Metal details colour LHC4.
CAMILA chair. LO01/1 RTM. cm 50x60x79 h. Chair covered with Bouclé fabric LO01/1. Metal structure colour Tuscany Red.
MOON mirror. 118RLC4. cm Ø 118x3. 80RLC4. cm Ø 80x3. Mirror composed by two mirror pieces and one Rosso Levanto inlay. Metal frame colour LHC4.





ASTER table. D/T160RLUTR. cm Ø 160x76 h. Rosso Luana top. Gloss lacquered wooden cylinder colour Tuscany Red. Metal details colour LHC4.
BELT chair. cm 57x52x78 h. Hard leather chair colour LC8.
ASTER console. 190RLUNPC4. cm 190x45x84 h. Rosso Luana top. Gloss lacquered wooden pedestal colour Tuscany Red. Metal details colour LHC4.
SOLARE table lamp. DIBN. cm 35x55 h. Desk lamp composed by a smoked glass element Ø 30 and marble element Ø 35. Black metal structure.



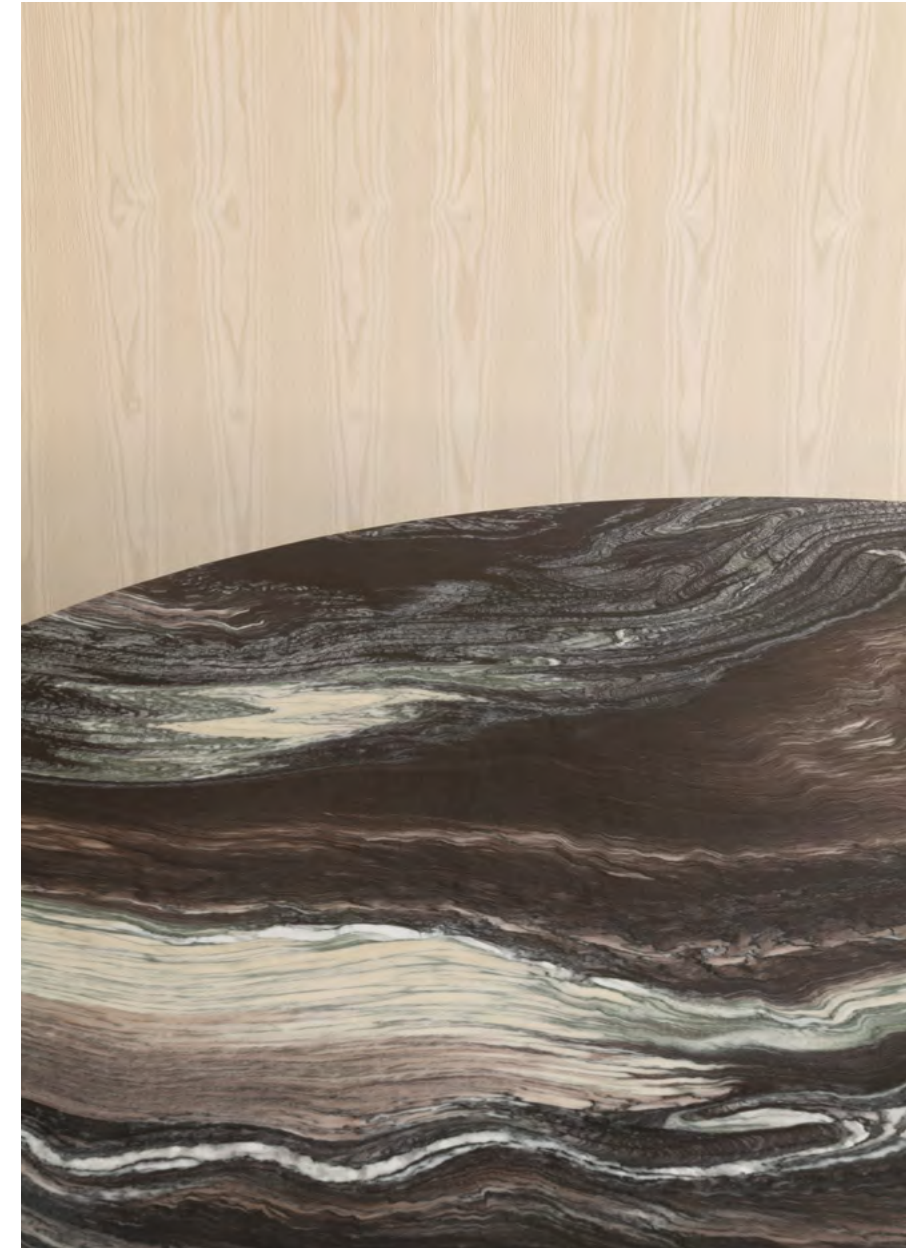



TOHO

Design Maurizio Manzoni

This "oriental treasure" is a secret of neatness and elegance. A thin line draws a smooth surface that surmounts pillars. The visual impact lends a feeling of inner peace, its image conveys calm to the scene. Toho shows no excess, no unreasonable pomp, but a refined balance of forms.





TOHO table. NM160LND.S. cm Ø 160x76 h. Nero Marquina round top. Monolithic pedestal with different pillar sizes. Metal details colour Dark Shadow.
MOVIE chair. LC5. cm 49x49x73 h. Hard leather chair colour LC5.





ZEN 2.0

Design Maurizio Manzoni

It stems from a conscious idea of sobriety that puts itself centre stage. The essence of Zen 2.0 is faithful to a single concept around which everything revolves: knowing how to listen to contrasts. From here arises order that slowly reveals itself from disorder, the asymmetry that becomes perfect, the contrast of materials such as marble and wood, so different yet so profoundly similar.



ZEN table. D/T 2700Y-NW. cm 270x120x76 h. Oyster marble top and inserts on bases. Walnut bases. Walnut bases. Central metal frame col. LHC4.
MOVIE chair. LC4. cm 49x49x73 h. Hard leather chair colour LC4.
CORE sideboard. OR-WNN. cm 243x50x73 h. Walnut wooden structure. Orabico marble sides and bottom details.
SOLARE table lamp. DIBN. cm 35x55 h. Desk lamp composed by a smoked glass element Ø 30 and marble element Ø 35. Black metal structure.









ZEN

Design Maurizio Manzoni

Every thought prefers the essential. Every meditation, whether precise or round, deep or barely sketched, provides well-being. Zen encapsulates this way of life. Its table top is a geometric manifesto of perfect imperfection, the supporting structure is an interplay of luminous marbles hidden in the soft shape of wood.



ZEN table. BC273DGN4. cm 273x107x74 h. Dark Grey ashwood table and pedestal. Bianco Carrara inlays on bases. Metal frame colour LHC4.
BELT chair. LC7. cm 57x52x78 h. Hard leather chair colour LC7.
HIRO cabinet. IGSSDS. cm 92x43x144 h. Satin Sand wooden structure. Dark Shadow metal details.





ZEN table. BC273DGN4. cm 273x107x74 h. Dark Grey aswood table and pedestal. Bianco Carrara inlays on bases. Metal frame colour LHC4.



OASI

Design Maurizio Manzoni

Where there is water, there is lush vegetation, there is life. Oasi has a sturdy inlaid wooden root on which a mirror rests that reflects arboreal colours. Oasi is an idea of discovery, a place of hoped-for beauty that reveals itself to our eyes, emerges from the ordinary and makes it come alive.

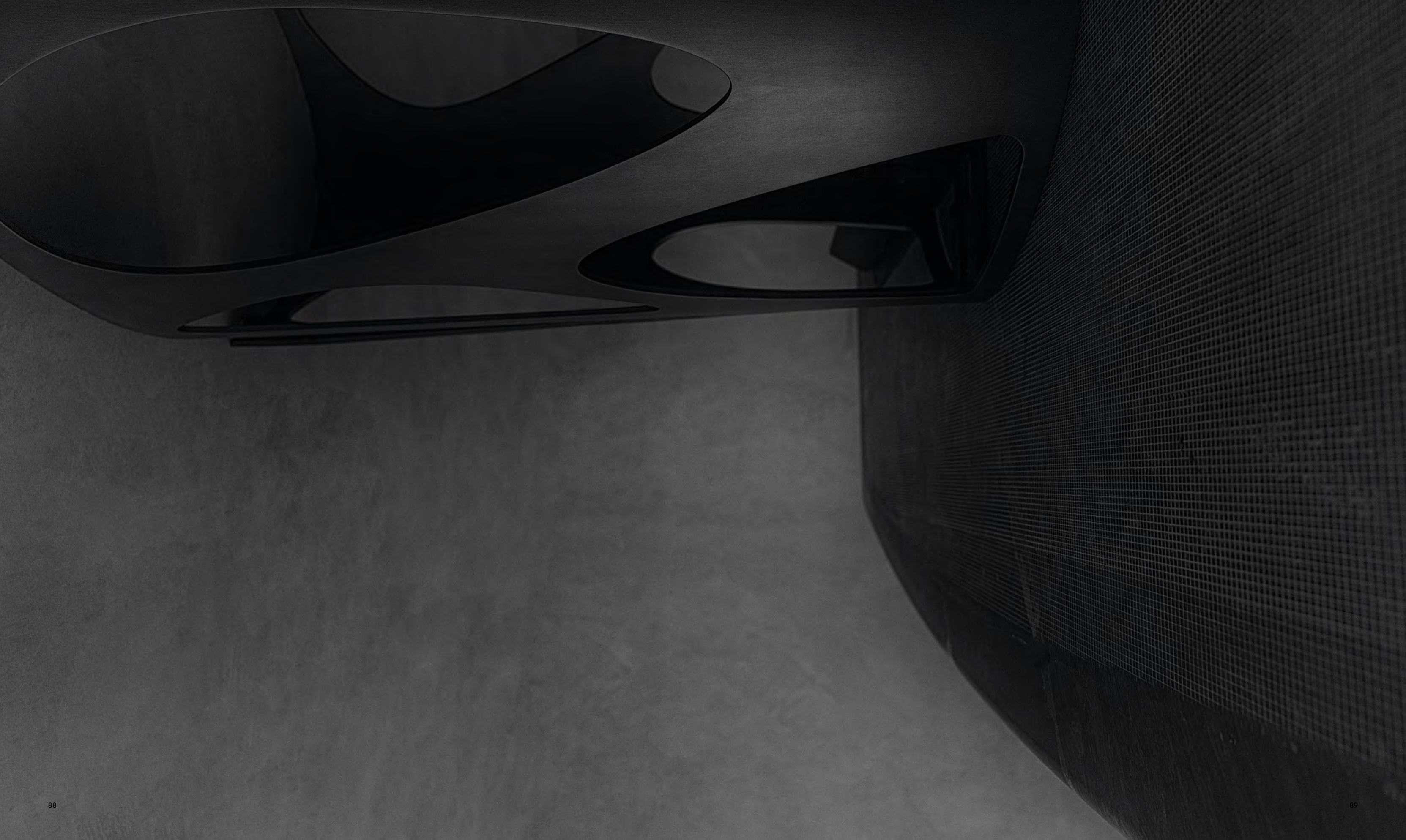



OASI table. 260GDNPDS. cm 260X115X76 h. Grigio Damasco top. Metal pedestal and metal frame colour Dark Shadow.
IYY SLIM chair. LC4BC. cm 57x59x79 h. Hard leather chair colour LC4. Bianco Carrara details.







COSMOS

Design Maurizio Manzoni

The chaos of matter always calls for a principle of order, of harmony of forms. Two concentric circles on the top correctly define this principle and depict it: a wooden disc that protects its precious marble core. This balance between the two materials remains in the base structure: three support points positioned on three identical angles, yet so undeniably different.



COSMOS table. CA180ADG. cm Ø 180x76 h. Dark Grey ashwood top. Inserted Lazy Susan realised in Calacatta. Bases crafted in Dark Grey ashwood and Calacatta. Metal frame colour LHC4.

MOVIE chair. LC5. cm 49x49x73 h. Hard leather chair colour LC5.



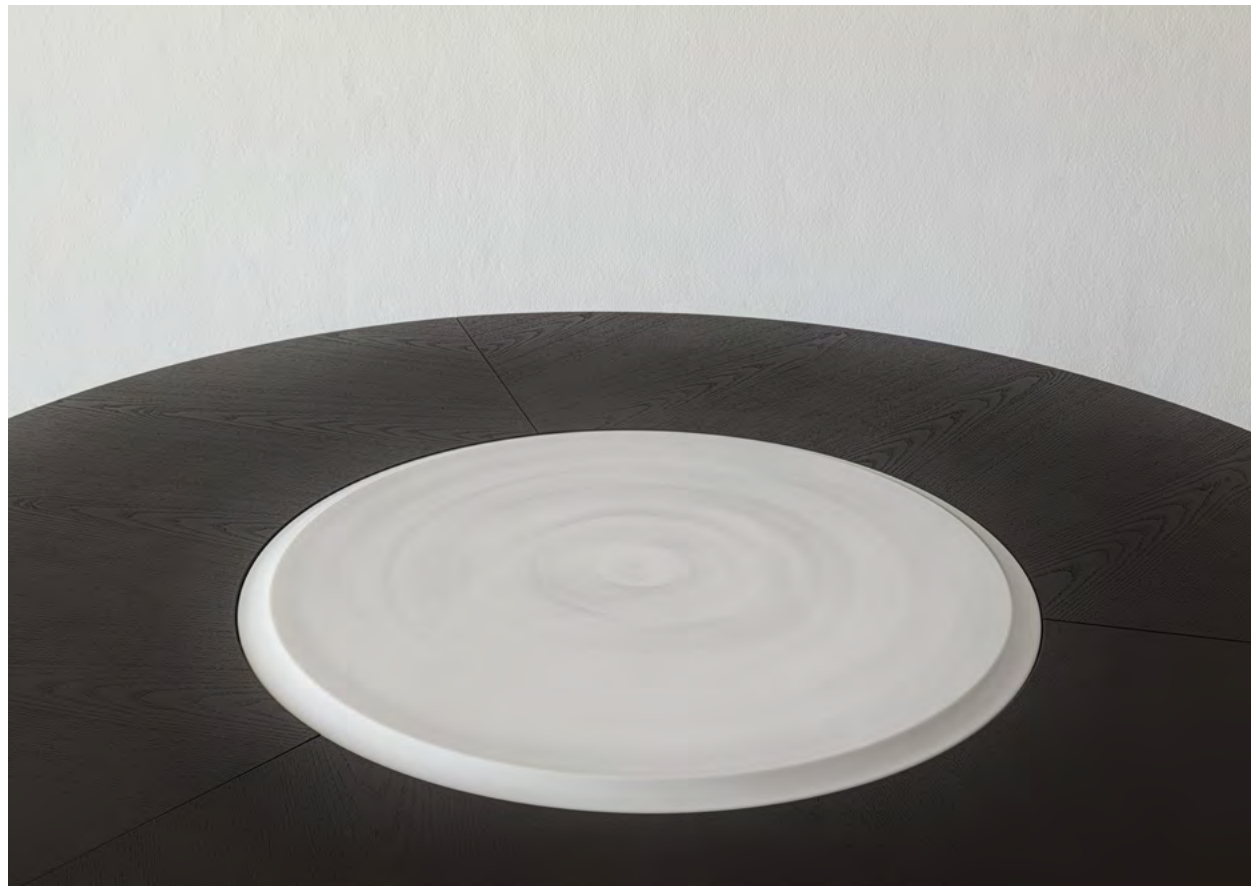

Inserted Lazy Susan realised in Calacatta.





ORION

Design Maurizio Manzoni

A shape that amazes more for the light it radiates than for its mere dimensions. Orion enhances an essential style, it knows how to convey a vivid image of itself, it is simplicity that manages to manifest itself with an uproar. Grace and vertical symmetry, measure and horizontal beauty: every detail of it is inspired by the brightest constellation.



ORION table. 240x120x76 h. Bianco Lilla Oval top. Bianco Lilla pedestal with central chrome element.
BELT chair. LC7. cm 57x52x78 h. Hard leather chair colour LC7.







ECHO

Design Maurizio Manzoni

A message from the past passed through the rock and came to us in the writing of light and dark veins. Echo brings to light a sound that has become solid after endless reflections, remaining trapped in matter, crystallised. Its image is evident on the table top, but its origin can be appreciated even more in the details of the three-dimensional development of the base.



ECHO table. WP160INP. cm Ø 160x76 h. White Panda top and bases.
Pedestal displaying a unique alternation of marble and stainless-steel metal elements.

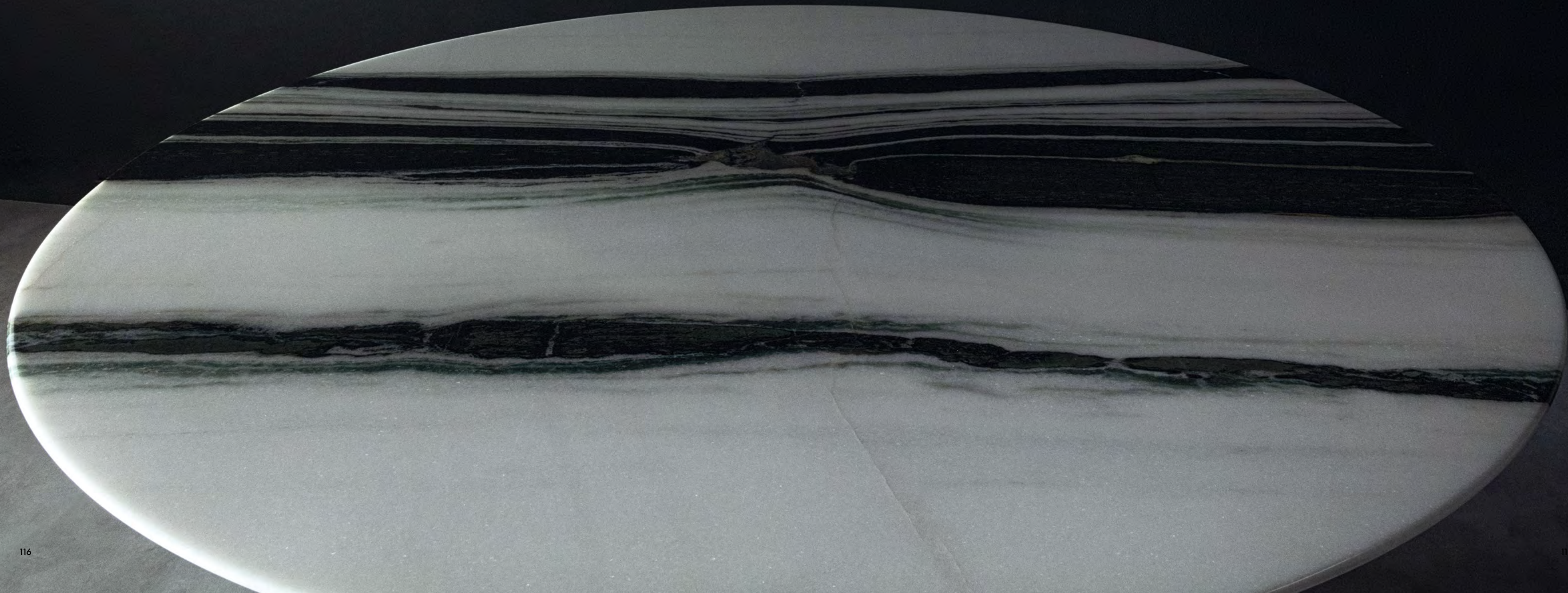

ECHO table. WP160INP. cm Ø 160x76 h. White Panda top and bases. Pedestal displaying a unique alternation of marble and stainless-steel metal elements.
IVY chair. ARMIC1BC. cm 58x59x73 h. Hard leather armchair colour LC1. Front metal pedestal colour LHC5. Bianco Carrara details.
LAYER sideboard. 240ABWPDS. cm 240x43x86 h. Sideboard in White Panda top, side and details. Black ash wooden structure. Metal details colour Dark Shadow.







A metal latticework with marble cladding, linear strength and solid charm. Liam proposes an idea of solid beauty, making its own the conviction that lies in every original design idea and that a few precise lines can always define solutions of absolute effectiveness and unquestionable style.









LIAM table. 260CAIDS. cm 260x115x76 h. Calacatta top and bases. Metal frame colour Dark Shadow. Marble bases with inox trim.
IIVY SLIM chair. LC4BC. cm 57x59x79 h. Hard leather chair colour LC4. Bianco Carrara details.
CORE sideboard. 240CADGAC4. cm 243x50x73 h. Dark Grey ash wooden structure. Calacatta sides and bottom details. Metal details colour LHC4.
ELIO mirror. 146KBC4. cm 146x114x5. Mirror composed by 4 mirror sections and a Kenya Black inlay. Metal frame colour LHC4.

C

Being original. Interpreting the origins and discovering that beauty, to be so, always needs to be complete, but imperfect. And that there are objects that do just that, make beauty complete. They are like silent notes, therefore imperfect, at the moment when all the instruments of the orchestra fall silent in unison and last for the time of a pause. The ear listens to that very moment, aware that that silence can never again equal itself.

LENZI
HOME COLLECTION



C



CAMILA

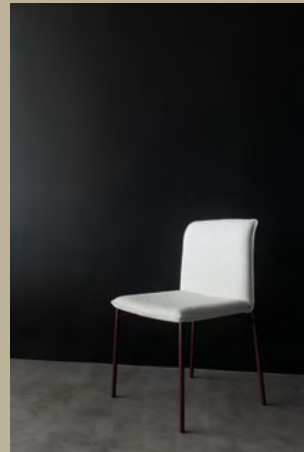

BELT



IVY SLIM

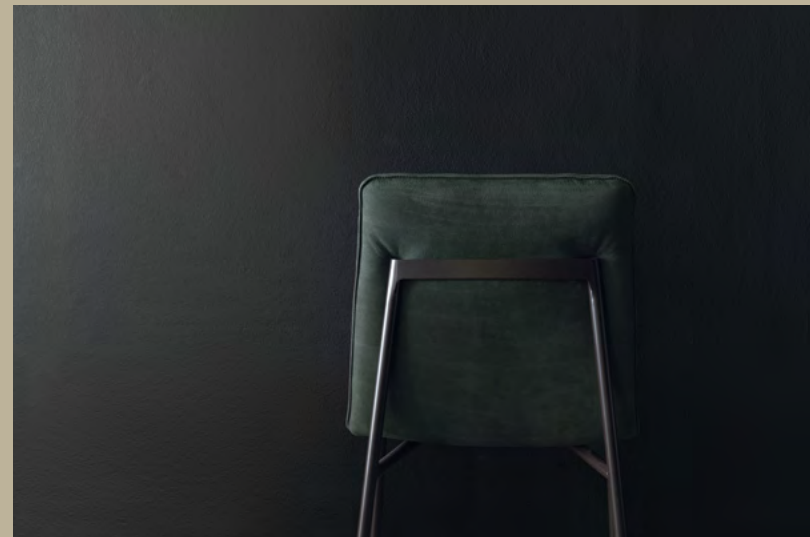
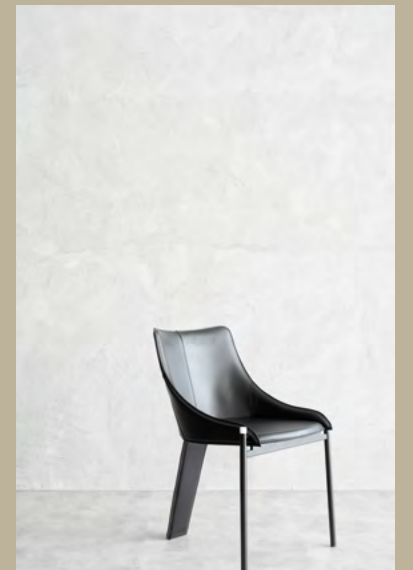
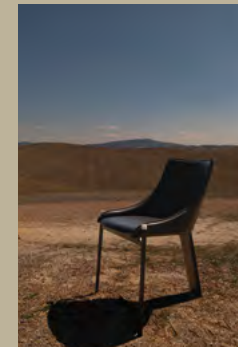

IVY



MOVIE



CAMILA

Design Maurizio Manzoni

Essential is all that simply is, like elegance that seeks no fuss. Camila is light, ethereal, a neutral backdrop that simply enhances the lively spirit of the table to which it may be paired.





CAMILA chair. LO01/1 RTM. cm 50x60x79 h. Chair covered with Bouclé fabric LO01/1. Metal structure colour Tuscany Red. Previous pages. **CAMILA** chair. LN24C5. cm 50x60x79 h. Chair covered with Nubuck LN24. Metal structure colour LHC5.

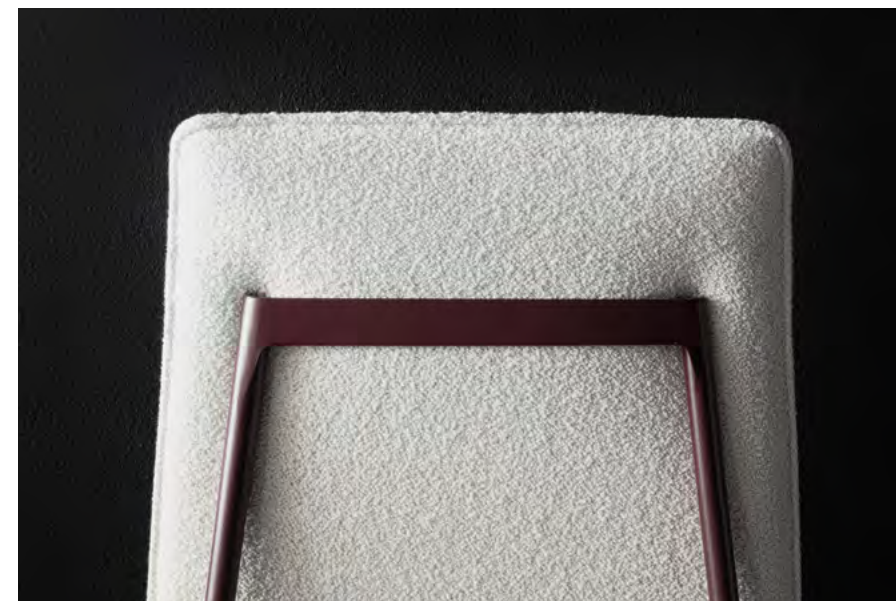

MOVIE

Design Maurizio Manzoni

Listening to the silence and understanding its meaning, while all around there is peace and the scene is about to get filmed by our mind. Movie can wind the tape of thoughts and hold in a hug those who abandon themselves to it.





MOVIE chair. LC5. cm 49x49x73 h. Hard leather chair colour LC5.

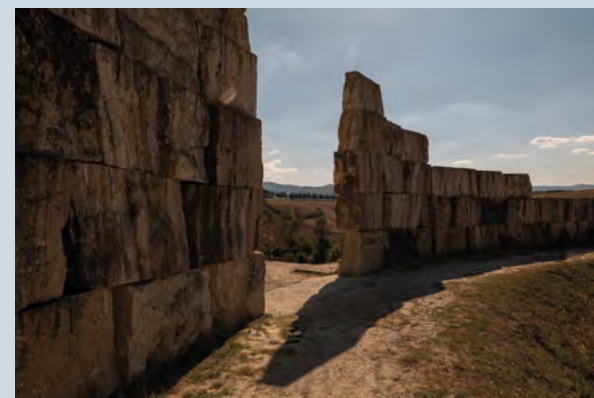

BELT

Design Maurizio Manzoni

Romantic soul and light-hearted refinement. Belt makes the scene important and gives it the discreet charm which is typical of the light old pink colour.



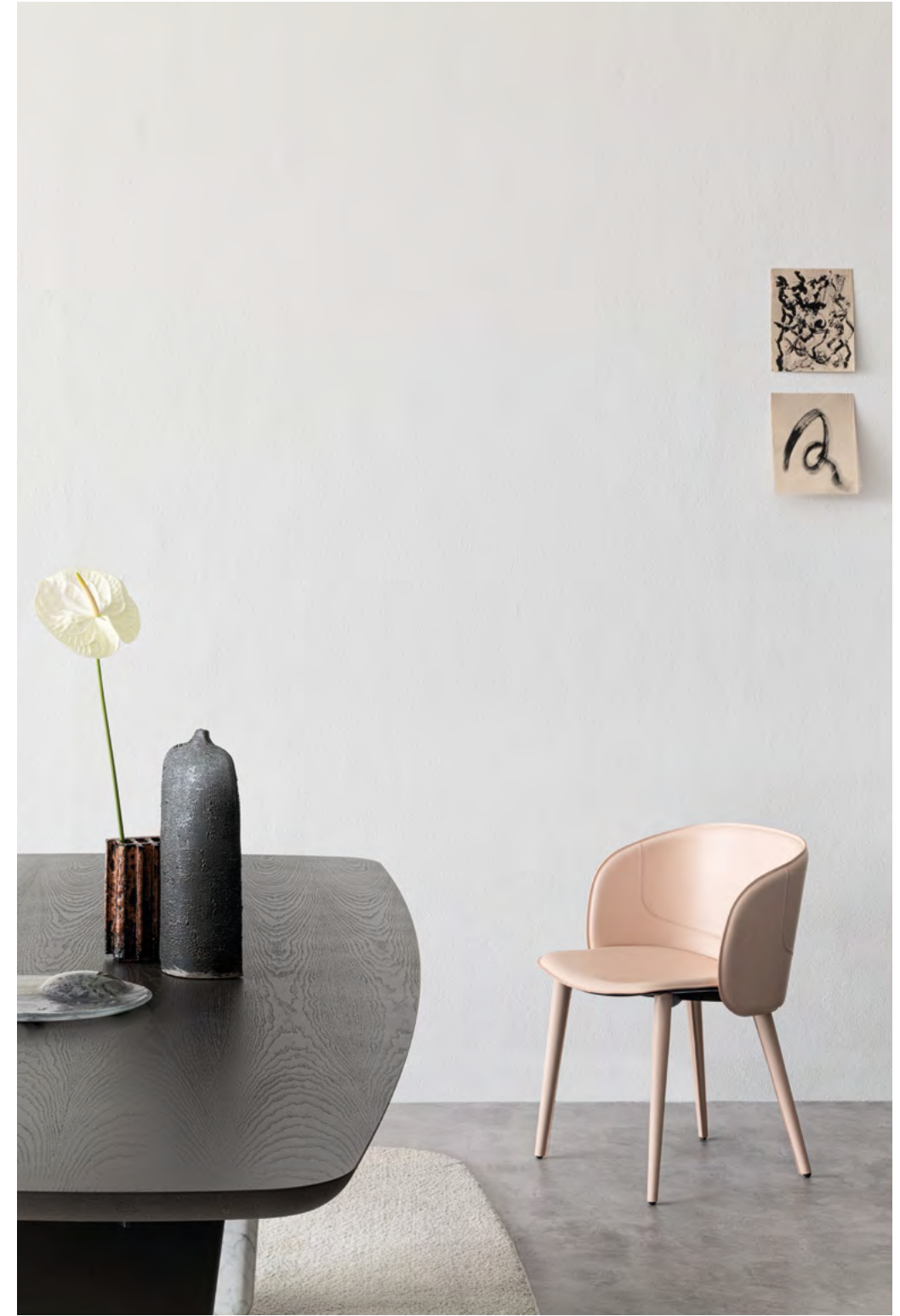

BELT chair. LC7. cm 57x52x78 h. Hard leather chair colour LC7.



IVY SLIM

Design Maurizio Manzoni

The allegiance to a precise design idea has found its clearest geometric expression. Ivy wants to be a symbol of innovation and at the same time a manifesto of continuity and consistency. The desire to be original rejoins tradition, it entwines to it like ivy.





IVY SLIM chair: LC4BC. cm 57x59x79 h. Hard leather chair colour LC4. Bianco Carrara details.



IVY SLIM chair. LC4BC. cm 57x59x79 h. Hard leather chair colour LC4. Bianco Carrara details.
IVY chair. ARMIC1BC. cm 58x59x73 h. Hard leather armchair colour LC1. Front metal pedestal colour LHC5. Bianco Carrara details.



Ivy becomes even more welcoming in the version with armrests. An actual throne to contemplate the beauty of the space around. An object that stands out also thanks to the marble detail on the two front pedestals.







S

Be original. Redefine the very concept of "point of view", without distorting the meaning of what you want to portray. Hills that become a large room to furnish, spaces made of silence and pleasant waiting, the style that makes the landscape different, although it is influenced by it. A mutual exchange: creativity and matter, dream and substance, opposite phases that complement each other.

LENZI
HOME COLLECTION

S

CLAUS



ADON



ARIES



HUG



CLIFF



CLAUS

Design Maurizio Manzoni

Simplicity should always be explored in depth to discover how elaborate it really is. Claus presents a sober image of itself and suggests soft comfort enclosed in simple, strong lines. But simply change the point of observation and a section of carved marble gives the scene a vigorous visual impact.





CLAUS sofa. 260LS01-2ORTR. cm 260x103x77 h. Fabric Zee col. LS01-2. Marble sides in Orobico.
IRIS armchair. LO09-23F/F. cm 82x92x70 h. Fabric Bouclé LO09-23. **IRIS** pouf. LO09/23. cm 60x60x37h. Fabric Bouclé LO09-23.
EOS H end table. TOP NOCE 60. cm Ø 60x45 h. Walnut top. Bianco Carrara solid pedestal.



CLAUS sofa. 260x103x77 h. Fabric Zoe col. LS01-2. Marble sides in Orobico. Metal pedestal col. LHC10.
NEBULA coffee table. 90xALHC10. cm 90x85x32 h. Calacatta top. Metal pedestal col. LHC10.
NEBULA coffee table. 140ORLHC10. cm 140x73x28 h. Orobico top. Metal pedestal col. LHC10.
SOLARE floor lamp. FLBN. cm 46x183 h. Floor lamp composed by two smoked glass elements size Ø 35 and Ø 42 and one marble element Ø 30. Black lacquered metal finish.





CLAUS sofa. 260LS01-2ORTR. cm 260x103x77 h. Fabric Zoe col. LS01-2. Marble sides in Orobico. Metal pedestal col. LHC10.



HUG

Design Maurizio Manzoni

A hug would be enough for the unsettled tension of our time to dissolve completely. Hug invites its guests to experience happiness, its generous shapes infuse calm and instil a taste for tactile surfaces. Its style celebrates the secret voluptuousness of marble, whose discreet presence has an almost symbolic value, like a trademark.





HUG sofa. 240x102x68 h. Sofa in leather LI15. Calacatta marble sides details.
GEMINI coffee table. 120x60x35 h. Smoked Glass top. Two solid Bianco Carrara elements. One metal element. metal colour Dark Shadow.
SOLARE floor lamp. FLBN. cm 46x183 h. Floor lamp composed by two smoked glass elements size Ø 35 and Ø 42 and one marble element Ø 30. Black lacquered metal finish.



HUG sofa. 240x102x68 h. cm 240x102x68 h. Sofa in fabric Bouclé col. LO01-1. Calacatta marble sides details.
HUG armchair. B1098. cm 76x81 x65 h. Armchair realised in Bouclé LO098/125. Swivel base.
NEBULA coffee table. 140OSDS. cm 140x73x82 h. Ocean Storm top. Metal base colour Dark Shadow.
NEBULA coffee table. 90GRDS. cm 90x85x32 h. Grey River top. Metal base colour Dark Shadow.







HUG sofa. 240|1001-1. cm 240x102x68 h. Sofa in fabric Bouclé col. 1001-1. Calacatta marble sides details.
HUG armchair realised in Nubuck LN25. Swivel base.
EOS H end table. TOP NOCE 60. cm Ø 60x45 h. Walnut top. Bianco Carrara solid pedestal.
EOS L coffee table. L38 GTBC. cm 90x60x38 h. Smoked glass top. Bianco Carrara solid pedestal.
NEBULA coffee table. 140OSDS. cm 140x73x82 h. Ocean Storm top. Metal base colour Dark Shadow.

ADON

Design Maurizio Manzoni

Effectiveness is the most recognisable talent of modernity. Adon leaves no room for uncertain lines and does not seek sleight of hand, it does not grant any excess to elegance and it almost takes pleasure in his very precise, yet simply beautiful nature.



ADON sofa. 270LG20C. Casual version, cm 270x99x75 h. Sofa in leather LG20. Inox structure. Bianco Carrara details.
GLOW coffee table. 80GDNPC4. cm Ø 80x40 h. Smoked glass top. Grigio Damasco lower top. Metal LHC4.



ADON sofa. 270LG20CLA. Class version. cm 270x99x75 h. Sofa in leather LG20. Inox structure. Bianco Carrara details.
HUG armchair. B1098. cm 76x81 x65 h. Armchair realised in Bouclé L0098/125. Swivel base.
ASTER side table. S/156EGC4. cm Ø 56x60 h. Lacquered wooden top and base colour English Green. Metal detail colour LHC4.
ASTER coffee table. C/T900SA. cm Ø 90x30 h. Coffee table realised in Ocean Storm top. Dark Grey ashwood cylinder. LHC4 metal structure.





ARIES

Design Maurizio Manzoni

It is extraordinary how reason and impulse can often coexist in some ideas. If the first contains elements of strength, the second leaves room for pleasant weaknesses. Aries conveys this idea: the large seats are arranged on a structure fortified by a horizontal cylindrical beam, at the ends of which fascinating marble plates of instinctive beauty are attached.



ARIES sofa. 260x106x80 h. Sofa in fabric Grace LAD03. Marble sides crafted in Bianco Lilla. Inox structure. Hard leather panels colour LC4.
HUG armchair. LN25. cm. 76x81x65 h. Armchair realised in Nubuck LN25. Swivel base.
CORO coffee table. 150IGNPDS. cm 150x70x35 h. Coffee table realised in Invisible Grey marble and lacquered wooden element col. Satin Sand. Metal structure colour LHC4.
STILETTO floor lamp. FLBN. cm 22x170 h. Floor lamp composed by a unique black metal structure and 3 different heights translucent marble columns.







CLIFF

Design Maurizio Manzoni

Let yourself fall and descend into pleasure. Cliff welcomes those who abandon their bodies to their own well-being, those who let themselves go with no fear, because they know they will eventually land on a precious net which protects their body and a soft quietness that takes care of their mood.



CLIFF sofa. 260LN12. cm 260x104x81 h. Leather sofa in Nubuck LN12. Metal details LHC4. Armchair side details in Bianco Carrara.
GEMINI coffee table. 120SGBCDS. cm Ø 120x35 h. Smoked Glass top. Two solid Bianco Carrara elements. One metal element. metal colour Dark Shadow.



CLIFF paoline. PAOIPO4LHC4. cm 240x104x81 h. Paoline in Fabric LPO4. Metal details LHC4. Armchair side detail in Bianco Carrara.
GEMINI side table. ST57BCC5. cm 57x40x55 h. Smoked glass top. Solid Bianco Carrara element. Metal colour LHC7.



A

Be original. Search for the origin of beauty in the details, without being distracted by the whole. Fragmenting the passion into a thousand pieces of a puzzle, ensuring that it does not get lost, but rather focuses on the single detail.

LENZI
HOME COLLECTION



A

IRIS



MAIA



HUG

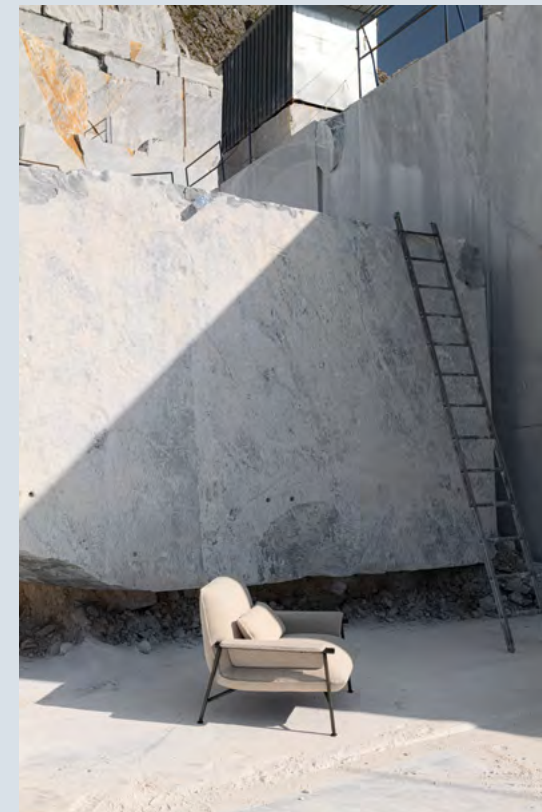
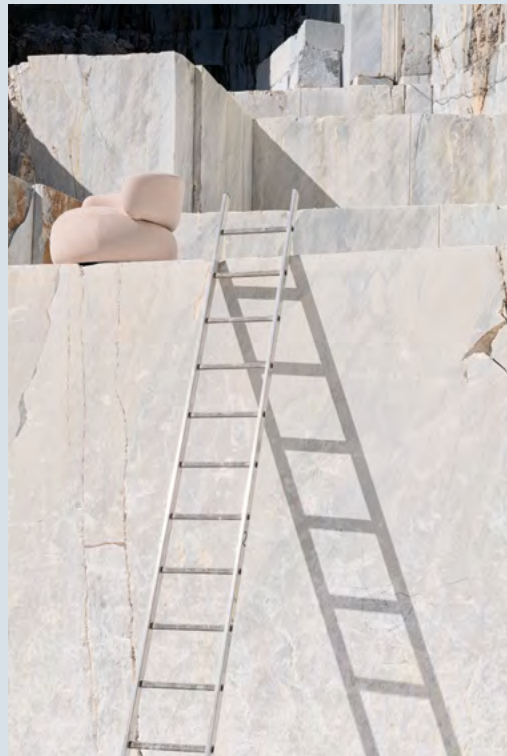

IRIS

Design Maurizio Manzoni

Sobriety that astonishes by what it masks and finally shows of itself, only to the eyes of those who know how to observe it. Iris is a small masterpiece that offers a dedicated experience of comfort, an individual and exclusive adventure.





IRIS armchair. LO09-23F/F. cm 82x92x70 h. Fabric Bouclé LO09-23.
IRIS armchair. F/M LO01/1. cm 82x92x70 h. Fabric armchair with Orobico marble sides.







IRIS armchair. LO09-23F/F. cm 82x92x70 h. Fabric Bouclé LO09-23. **IRIS** pouf. LO09/23. cm 60x60x37 h. Fabric Bouclé LO09-23.

HUG

Design Maurizio Manzoni

The circle aspires to perfection, gets to touch it, keeps chasing it but can never reach it. Because perfection is boring, like a continuous straight line. The armchair Hug was designed by a compass left to itself, rotated on two axes rolling into space, one after the other, until obtaining the shapes and emotions of a hug.







MAIA

Design Maurizio Manzoni

There are objects that immediately establish the style of an ambience, whatever the ambience. Because very often it is a single detail that gives life to an entire scene and Maia has the richness of detail and the versatility necessary to fulfill this purpose.





MAIA armchair. LO01-2. cm 89x87x70 h. Armchair in Bouclé fabric LO01-2. Metal structure LHC4.
NEBULA coffee table. 90GRDS. cm 90x85x32 h. Grey River top. Metal base colour Dark Shadow.



S

Be original. Reaching out the core of the ideas, the point where they originated, which is actually the beating heart of a project, what keeps it alive and makes it progress. Start from that point and extend across the plane, then duplicate it by adding new layers, then multiply them in space.



LENZI
HOME COLLECTION

S

LAYER



HIRO



VESTA



ALDER



PILOTIS



CORE



ASTER



FINN



LAYER

Design Maurizio Manzoni

Like the layers of a rock, each one with its own history. Or like the memories that sediment within us, each one with its own meaning. Everything that is alive is also dynamic, it has within itself an idea of superimposed layers, we could call them levels. Layer is inspired by this concept: whoever observes it can distinguish the materials, one from the other, the colours so different from each other, the different heights that are hidden inside it, the precise horizontal and vertical divisions.



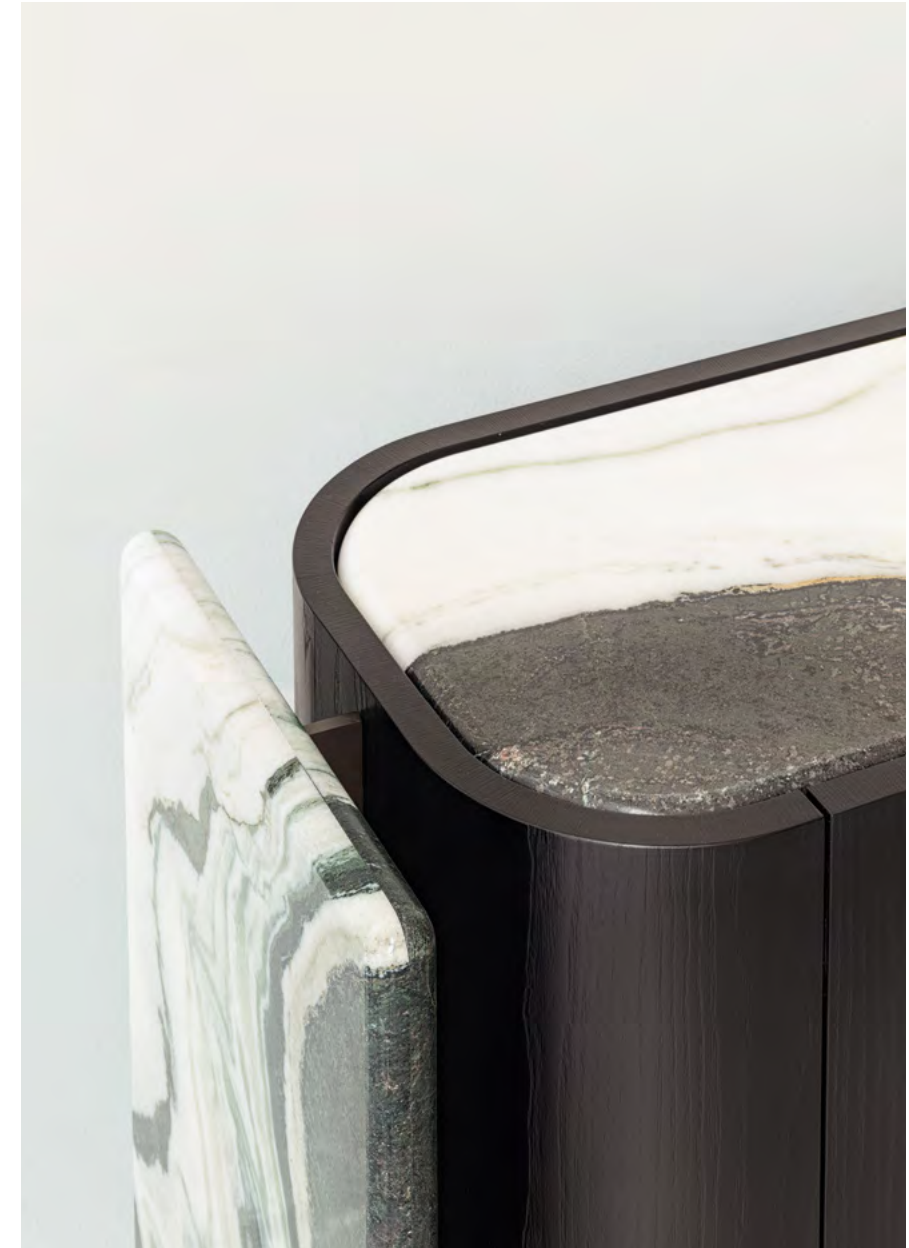



ALDER

Design Maurizio Manzoni

Nature has a passion for symmetry and in everything that exists in nature we may discover spatial symmetries. Alder puts these symmetries on stage, giving them shape and colour, so that wood and marble can coexist together, each material with its own density, each colour with its appropriate volume.









CORE

Design Maurizio Manzoni

A delicate heart and its indestructible shell need each other in order to be, to exist in harmony, to constitute an unbreakable unity. Core draws that image of mutual protection and its sight gives alternating emotions, depending on the angle from which you observe it: light and dark, strong and tender, severe and brilliant, the veins of the wood and the marble grain.



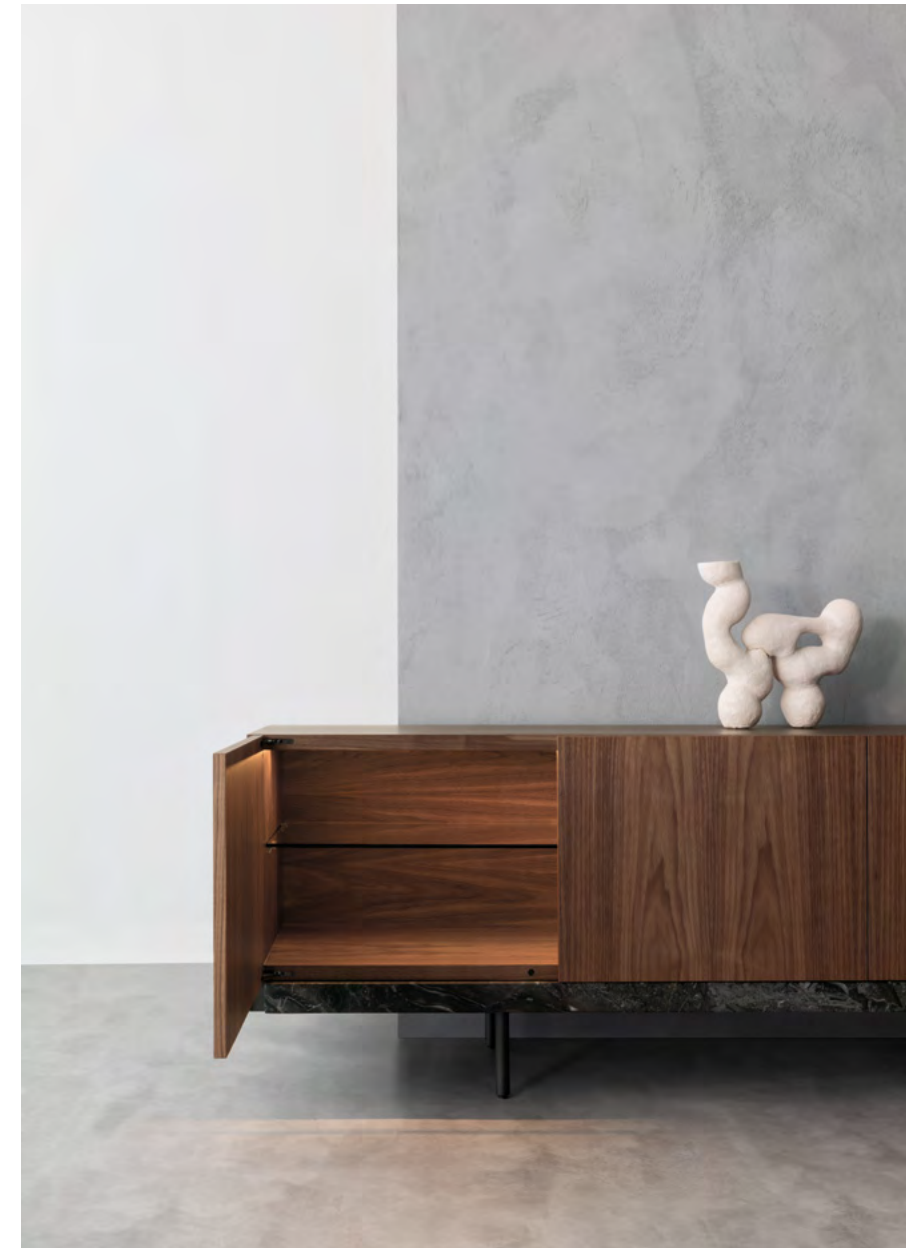



CORE sideboard. OR-WNN. cm 243x50x73 h. Walnut wooden structure. Orabico marble sides and bottom details.
HUG armchair. BL098. cm 76x81 x65 h. Armchair realised in Bouclé LO098 / 125. Swivel base.
ASTER side table S/T56AGLHC4. cm Ø 56x60 h. Calacatta top. Lacquered wooden base col. Ash Grey. Metal details col. LHC4.
ASTER coffee table C/T90AGLHC4. cm Ø 90x30 h. Lacquered wooden top and base col. Ash Grey. Metal details col. LHC4.
LOTO floor lamp. cm 28x150 h. Oyster marble, Bronze glass and chrome metal elements.



CORE sideboard. 240CADGAC4. cm 243x50x73 h. Dark Grey ash wooden structure. Calacatta sides and bottom details. Metal details colour LHC4.
MAIA armchair. LO01-2. cm 89x87x70 h. Armchair in Bouclé fabric LO01-2. Metal structure LHC4.







HIRO

Design Maurizio Manzoni

The atmosphere of festive days and the respect we dedicate to our most awaited guest, perhaps offering him company, words and spirits: these pleasant habits of ours immediately make us think to the light. Because there is light in a street party, there is light in the eyes of those we appreciate and again light in the reflections of a good liqueur. Hiro is 'the great light', an attraction that cannot go unnoticed and calls everyone to meet each other.



HIRO cabinet. LCSSDS. cm 92x43x144 h. Satin Sand wooden structure. Dark Shadow metal details.
BELT chair. LC7. cm 57x52x78 h. Hard leather chair colour LC7.





PILOTIS

Design Maurizio Manzoni

Elegance is, it does not want to appear, and opulence often hides within its details. Pilotis is a generous fragment of beauty, marble suspended on steel, a construction of style.





PILOTIS console. 180ORLHC11. cm 180x48x84 h. Orobico marble top. Metal pedestals col. LHC11.



VESTA

Design Maurizio Manzoni

Concave steel that welcomes light and embellishes it with marble reflections. Vesta is a goddess of the home that conjures up images of hearth and domestic warmth.







VESTA console. 180GRLHC8. cm 180x46x84 h. Grey River marble top. Metal pedestal col. LHC8.



ASTER

Design Maurizio Manzoni

A decisive look, the bright colour of a precious detail, but also a direct gaze, a dazzling response. Aster is a console that looks like a visiting card: it presents itself effectively, without frills and without mincing words and immediately tells everyone who we are and not who we would like to be.

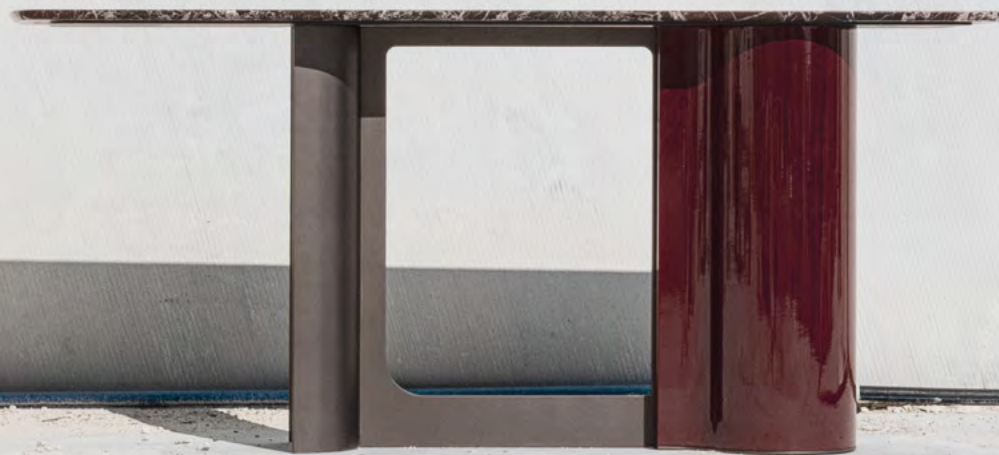
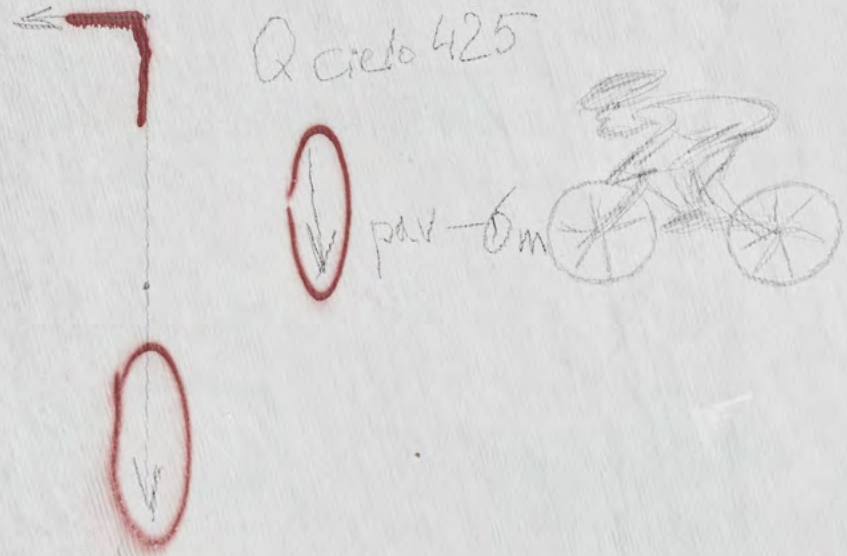

ASTER console. 190RLNPC4. cm 190x45x84 h. Rosso Levanto top. Gloss lacquered wooden pedestal colour Tuscany Red. Metal details colour LHC4.







ASTER console. 190RLUNPC4. cm 190x45x84 h. Rosso Luana top. Gloss lacquered wooden pedestal colour Tuscany Red. Metal details colour LHC4.

FINN

Design Maurizio Manzoni

Water and marble: so close yet so far. Different states of matter, very distant, united only by a thousand-year history. Yet the image created by placing them together seems perfect, because they both enhance the light and this lends vital energy to everything around them. The Finn console and its mirror reconstruct this image and crystallise it.





FINN console. WPLE175DS. cm 175x43x84 h. White Panda top, leather finish. Metal pedestal colour Dark Shadow.
FINN mirror. MIRWP70. cm 70x130x3. FINN mirror is composed by two mirror sections and two White Panda inlays. Leather finish. Metal details colour LHC4.

CT

Be original. In the truest sense of the term, looking at the origin by definition, which is Nature, and drawing inspiration from it. By not just taking note of the shapes, sometimes harsh, other times gentle, but in any case, always unique, original. But trying to perceive also, and above all, the intentions that hide behind those shapes, their most emotional meaning and what makes it so pleasant for us to observe them.

LENZI
HOME COLLECTION

CT

EOS



ASTER



GLOW



NEBULA



CORO



CORO

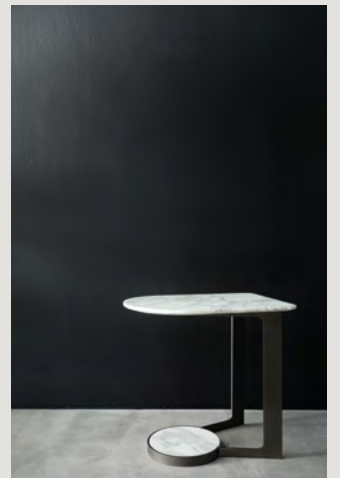

GEMINI



GEMINI

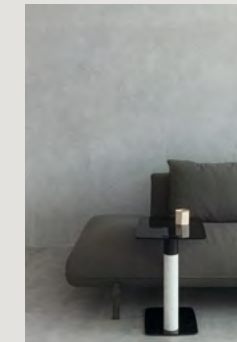

EOS

Design Maurizio Manzoni

A sunrise made of light stretching along the horizon and lying on a landscape of polished stone. Eos is an image that instils serenity, every detail suggesting that its form is a handcrafted sculpture.



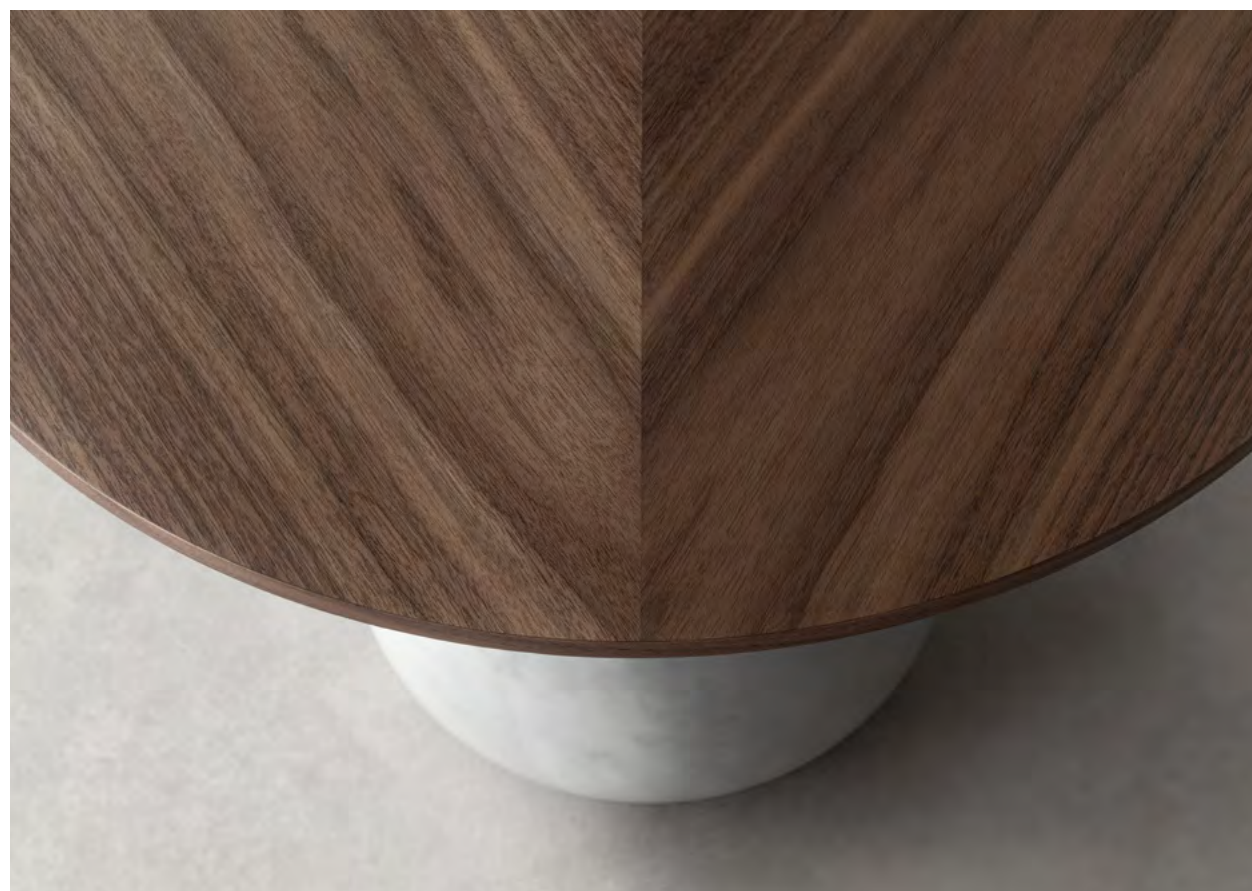
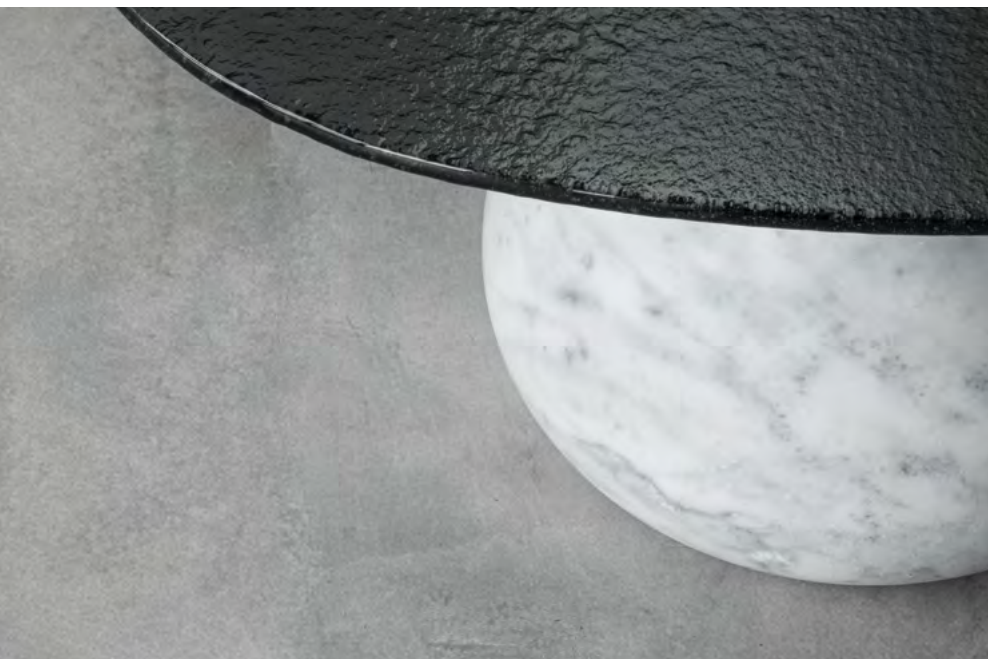

EOS H end table. TOP NOCE 60. cm Ø 60x45 h. Walnut top. Bianco Carrara solid pedestal.
EOS L coffee table. L38 GTBC. cm 90x60x38 h. Smoked glass top. Bianco Carrara solid pedestal.

ASTER

Design Maurizio Manzoni

Like a plant with roots in the ground, Aster showcases its robust central body, a resolute geometry that extrudes itself in height and on the top it shows off a watercolour of flowers, bright colours, imprinted forever in the rock.





ASTER side table. S/T56EGC4. cm Ø 56x60 h. Lacquered wooden top and base colour English Green. Metal detail colour LHC4.





ASTER coffee table. C/T900SA. cm Ø 90x30 h. Coffee table realised in Ocean Storm top. Dark Grey ashwood cylinder. LHC4 metal structure.

ASTER side table S/T56AGLHC4. cm Ø 56x60 h. Calacatta top. Lacquered wooden base col. Ash Grey. Metal details col. LHC4.
ASTER coffee table C/T90AGLHC4. cm Ø 90x30 h. Lacquered wooden top and base col. Ash Grey. Metal details col. LHC4.



GLOW

Design Maurizio Manzoni

It shines like a glowing meteor in the darkness of the universe. Glow is available in three different sizes, with marble tops and smoked glass, it's just a matter of choosing the one that best represents us.

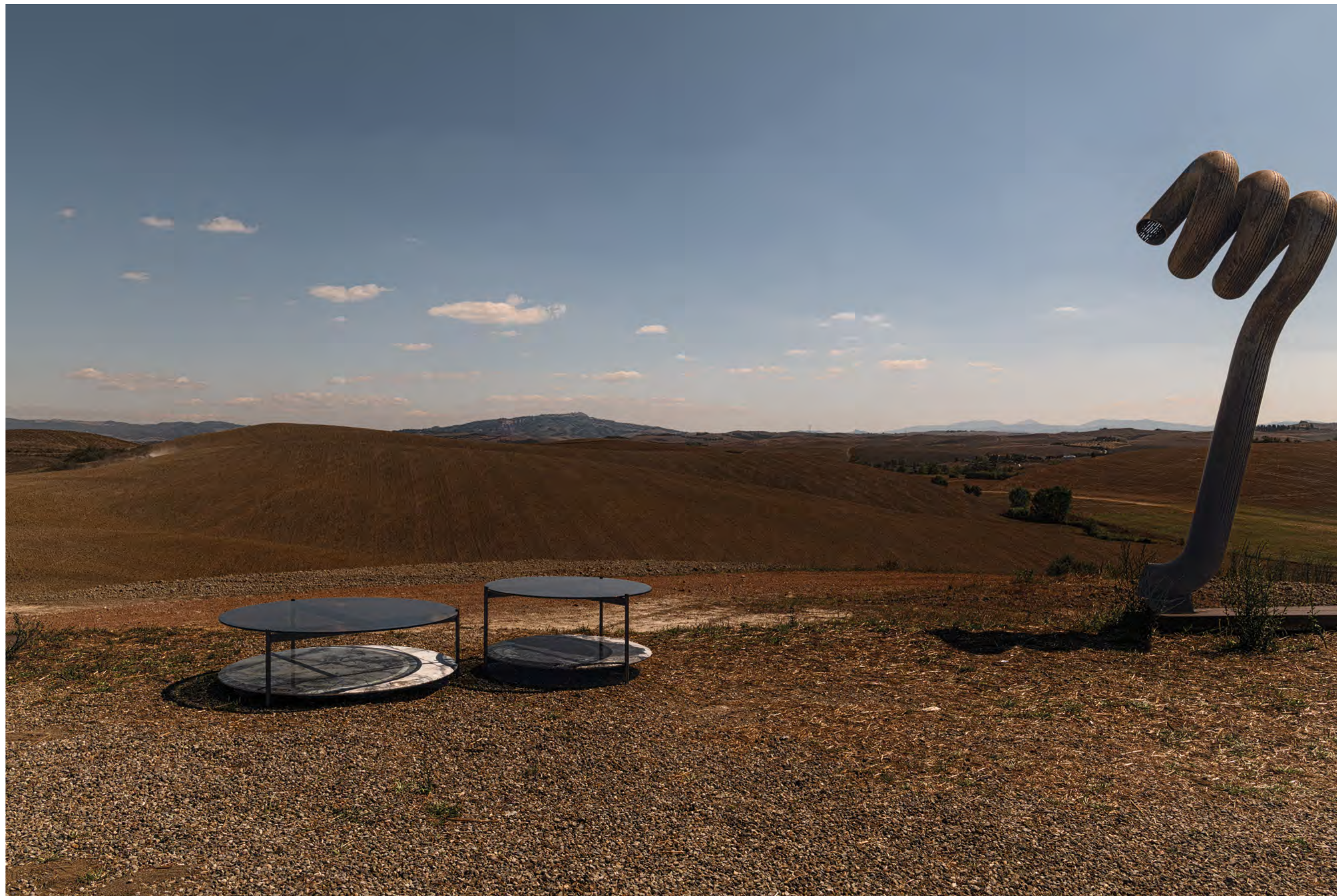



GLOW coffee table. 100IGNPC4. cm Ø 100x30 h. Smoked glass top. Invisible Grey lower top. Metal LHC4.
GLOW coffee table. 80GDNPC4 cm Ø 80x40 h. Smoked glass top. Grigio Damasco lower top. Metal LHC4.



NEBULA

Design Maurizio Manzoni

The morning dew is the breath of Nature, the great soul, which is alive and breathing through itself. Nebula is dedicated to Her and her raindrops which patiently mould the stone over time, giving it a soft shape.

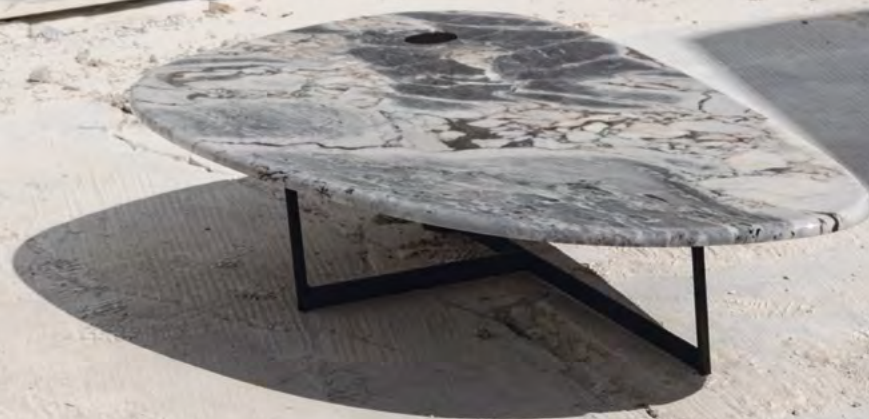



NEBULA coffee table. 140OSDS. cm 140x73x28 h. Ocean Storm top. Metal base colour Dark Shadow.





NEBULA coffee table. 90GRDS. cm 90x85x32 h. Grey River top. Metal base colour Dark Shadow.





NEBULA coffee table. 90CALHC10. cm 90x85x32 h. Calacatta top. Metal pedestal col. LHC10.
NEBULA coffee table. 140ORLHC10. cm 140x73x28 h. Orobico top. Metal pedestal col. LHC10.

CORO

Design Maurizio Manzoni

Each performing item of this composition is actually a soloist. Each voice of Coro is a different song, what holds them together is a vision of elegant harmony.



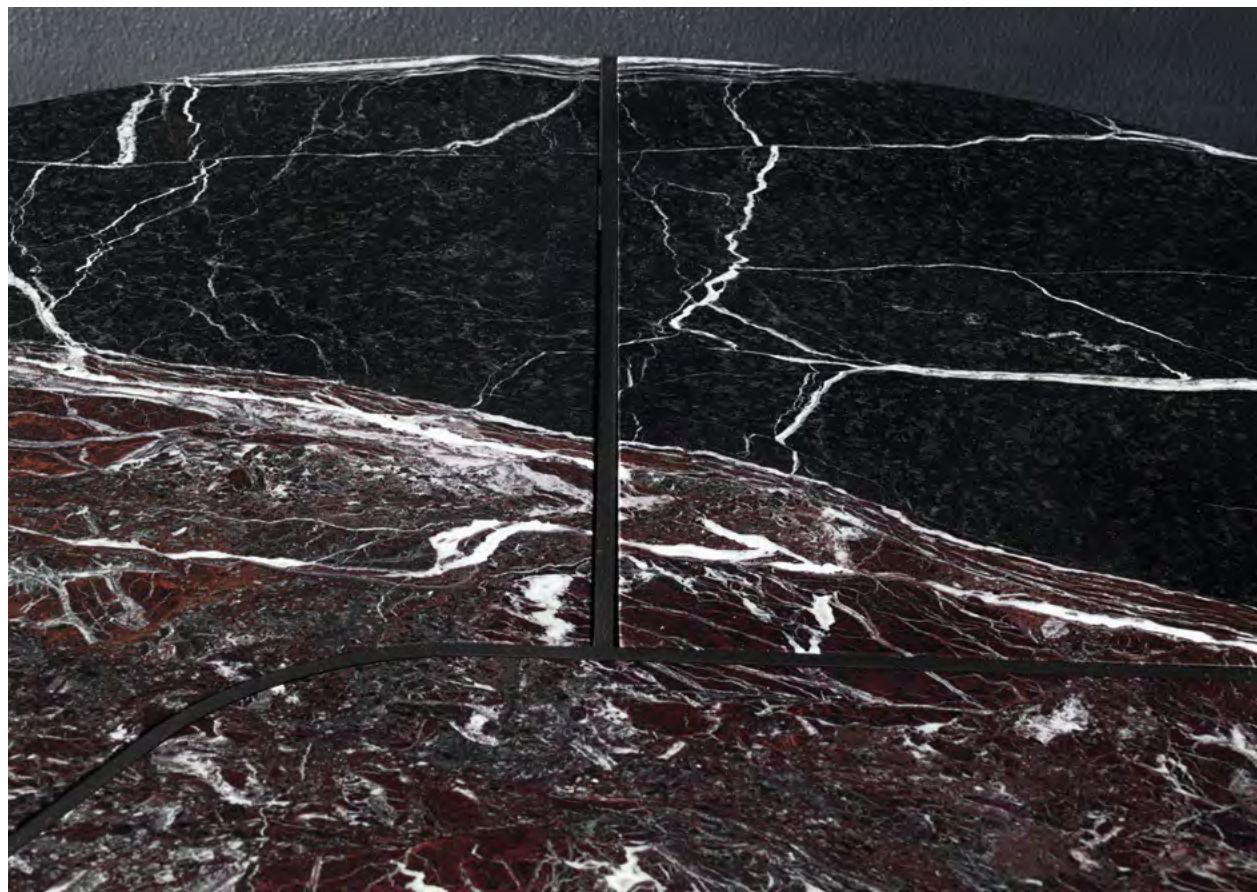

CORO coffee table. 115RLNPDS. cm Ø 115x30 h. Coffee table realised in Rosso Levanto. Metal structure colour Dark Shadow.





CORO coffee table. 150IGNPDS. cm 150x70x35 h. Coffee table realised in Invisible Grey Marble. Metal structure colour LHC4.
HUG armchair. LN25. cm 76x81x65 h. Armchair realised in Nubuck LN25. Swivel base.
STILETTO floor lamp. FLBN. cm 22x170 h. Floor lamp composed by a unique black metal structure and 3 different heights translucent marble columns.

CORO side table. 38CAC4. cm 38x50x50 h. Side table realised in Calacatta. Metal structure colour LHC4.
CORO side table. 38KBC4. cm 38x50x50 h. Side table realised in Kenya Black marble. Metal structure colour LHC4.



GEMINI

Design Maurizio Manzoni

It's not true that duality is necessarily an error, a deviation. Gemini's style offers a dual point of view: the angular profiles of the living material, visible to the naked eye, and the same profiles gently blurred by a dark lens.





GEMINI side table. ST57BCC5. cm 57x40x55 h. Smoked glass top. Solid Bianco Carrara element. Metal colour LHC7.



A

Be original. Let's appreciate with greater awareness what is around us and above our heads. Don't take for granted the wonder we feel when faced with the microscopic nature of things. Never again fear the mythical battles that take place in the sky.

LENZI
HOME COLLECTION

A

LOTO



SOLARE



STILETTO



MOON



ELIO

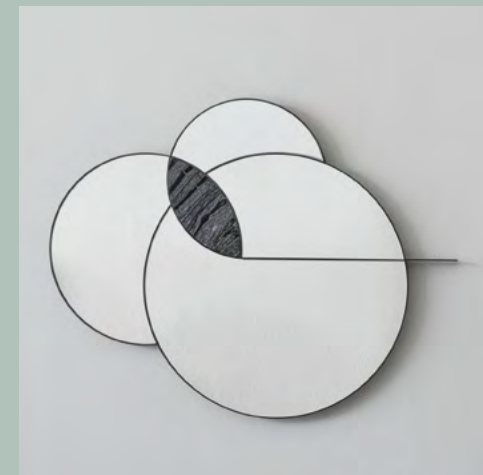

LOTO

Design Maurizio Manzoni

LOTO table lamp. cm 28x44 h. Oyster marble, bronze glass and chrome metal.



Amber petals that protect a soul of shining stone. Lotus is a secret to be glanced at, a flower that illuminates the home with rays of purity and well-being.





LOTO applique. cm 29x71h. Oyster marble, bronze glass and chrome metal elements.



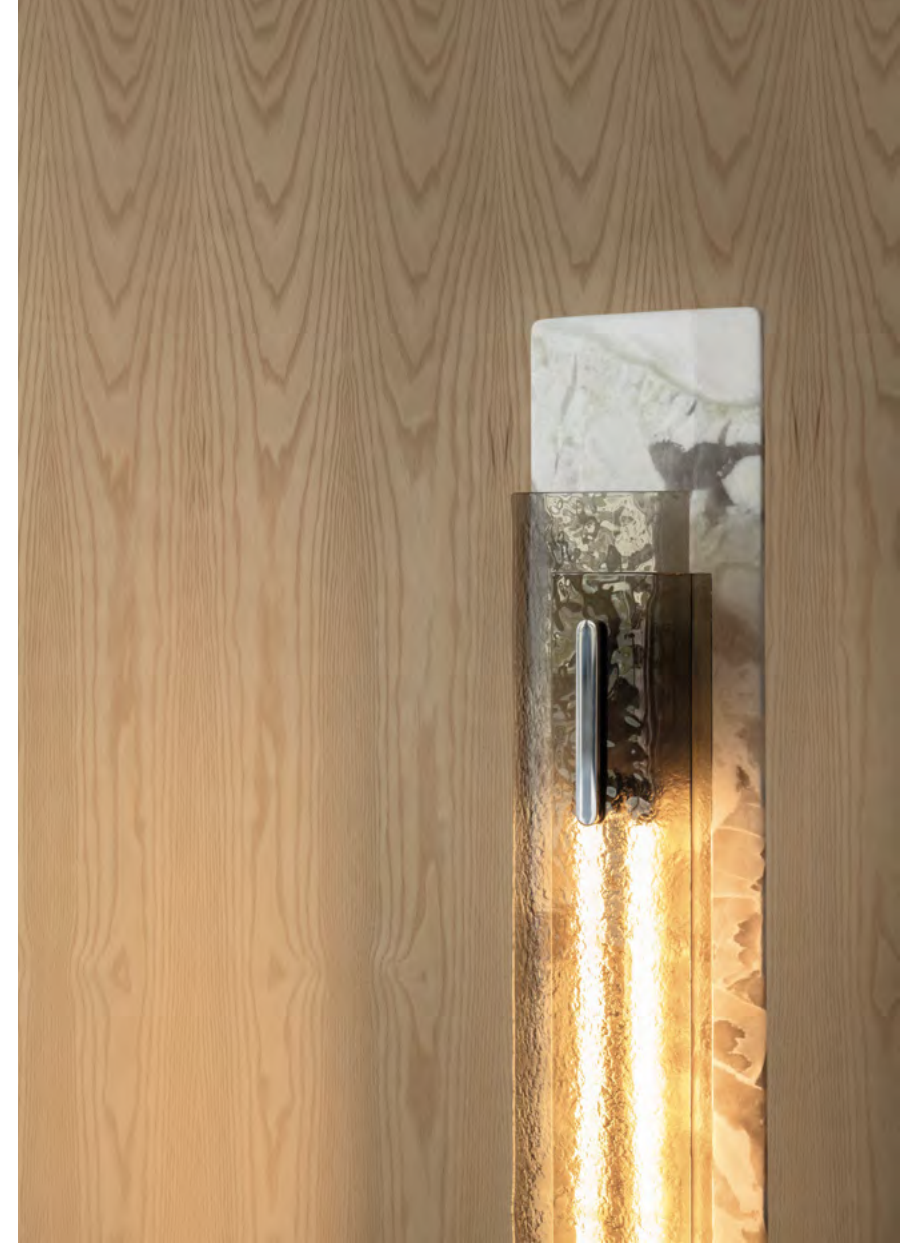

LOTO floor lamp. cm 28x150 h. Oyster marble, Bronze glass and chrome metal elements.

SOLARE

Design Maurizio Manzoni

According to the myth, the extraordinary events that occur in the celestial vault are always preceded by an eclipse. This is what Solare depicts: the eclipse of light that a metal, or a marble disk, generates when placed in front of a glass disk. The visual effect is a certain presage of leisure.

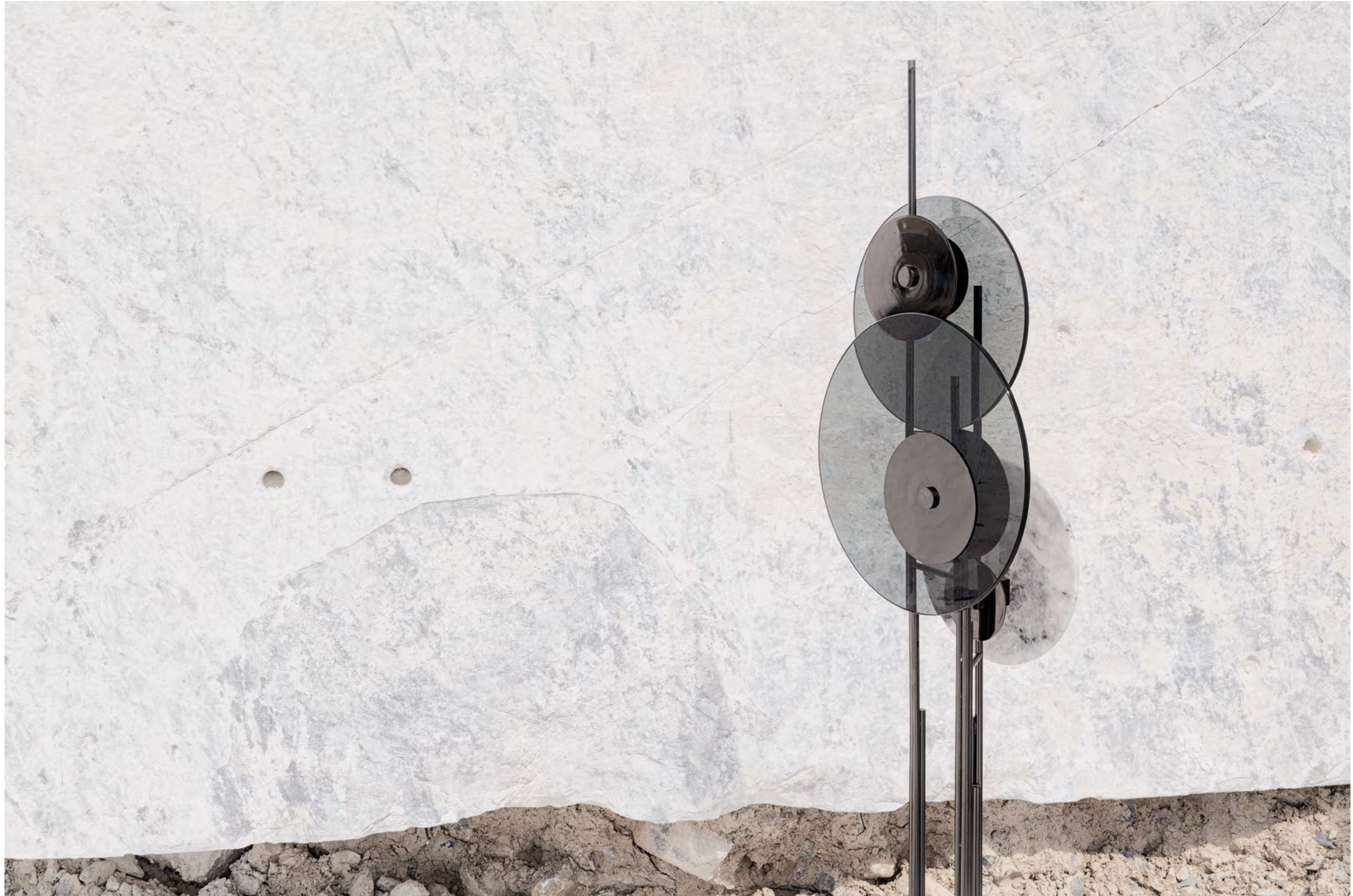



SOLARE floor lamp. FLBN. cm 46x183 h. Floor lamp composed by two smoked glass elements size Ø 35 and Ø 42 and one marble element Ø 30. Black metal finish.

SOLARE table lamp. DIBN. cm 35x55 h. Desk lamp composed by a smoked glass element Ø 30 and marble element Ø 35. Black metal structure.
SOLARE wall lamp kit composed by: SOLARE A-1. Smoked glass element Ø 35 cm. SOLARE A-2. Smoked glass element Ø 42 cm. SOLARE A-3. Marble element Ø 30 cm.



STILETTO

Design Maurizio Manzoni

City lights have dizzying heights and follow one another along the skyline. Stiletto resembles a frame of the horizon, a corner of the city in our home, but also a bundle of swords made of soft light.





STILLETTO floor lamp. FLBN. cm 22x170 h. Floor lamp composed by a unique black metal structure and 3 different heights translucent marble columns.
STILLETTO table lamp. DLBN. cm 30x45 h. Desk lamp composed by a translucent marble lamp shade with a black metal structure.

MOON

Design Maurizio Manzoni

Again the theme of the eclipse, this time of the Moon. And in this composition, the Earth is interpreted by its most precious rock, marble, while its satellite will be our reflected image.





MOON mirror. 118RLC4. cm Ø 118x3. 80RLC4. cm Ø 80x3. Mirror composed by two mirror pieces and one Rosso Levanto inlay. Metal Frame colour LHC4.



ELIO

Design Maurizio Manzoni

Like a feather, like a leaf sliding on the wind, like a molecule. Elio gives us back a look or a smile, the ones that a moment before belonged only to us. And in this reflected light it hides a reminder for us to be light-hearted.





ASTER

Design Maurizio Manzoni



Aster. A round table that is both very elegant and contemporary. This table merges perfectly three different materials: marble for the top, a wood cylinder, which can be produced in ash wood or lacquered, as the main part of the pedestal and a metal pedestal as the component of the base. The table design offers a variety of colour combinations and lends a symmetric movement to every ambience.

Table

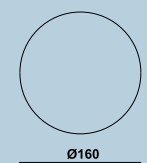
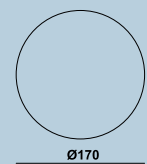
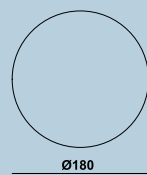
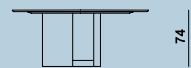

ATENA

Design Maurizio Manzoni

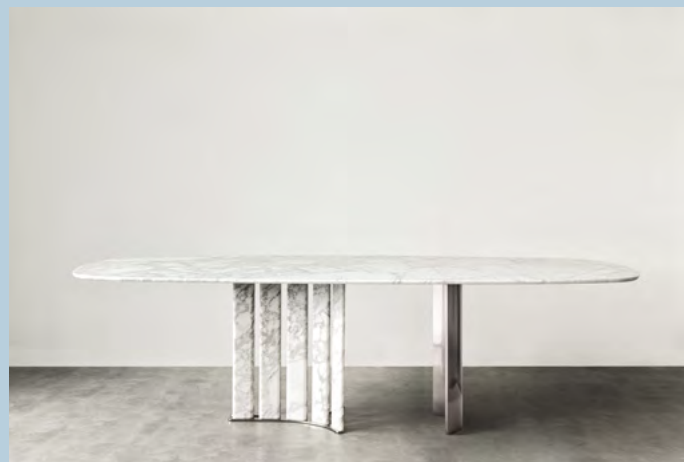

Atena. A design reminiscent of solid Greek temples revisited in a contemporary key. The symmetry of the individual elements and the alternation of empty and solid effects is embraced by the soft curve of the metal element that flanks them. A solid table with a contemporary design.

Table

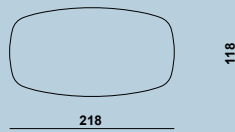
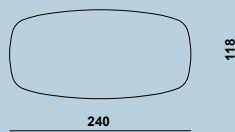
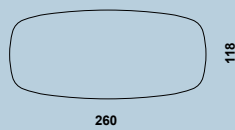

CLEPSY

Design Maurizio Manzoni



Solid and soft at the same time, made up of a solid marble base worked with sinuous lines. The combination with the walnut top contributes to the sense of elegance. A table where the materials offered to us by nature meet with the expert hand of the craftsman.

Table

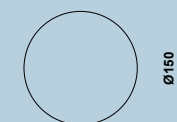
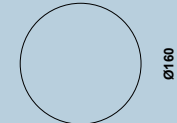
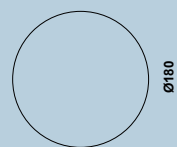
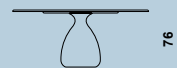

CORALLO

Design Maurizio Manzoni



Corallo. Table composed of a slightly shaped top and two marble bases formed by two inclined elements that embrace the central metal decoration. The design of the central element is reminiscent of the fascinating marine coral.

Table

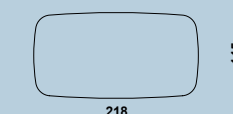
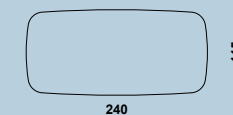
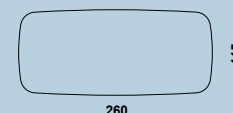

COSMOS

Design Maurizio Manzoni



Cosmos a round table with a strong personality. Composed of an ash wood top and twin bases, this table includes Lazy Susan marble at its centre, like Cosmos. The third pedestal, different from the other two for size and shape, has been crafted in marble. A metal frame connects the three pedestals to the top. Cosmos conveys elegance and functionality to any living room.

Table

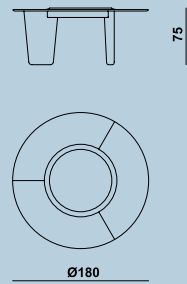

ECHO

Design Maurizio Manzoni



A dining table with a round marble top two centimetres thick. The composition of the elegant pedestal alternates between marble and metal, with an inox metal base. The tables featured are made of Invisible Grey marble. The Echo table plays on the contrast between the materials, geometrical lines and shapes, and the empty spaces. Marble and metal merge together in the smooth, rounded pedestal, producing an elegant and contemporary effect.

Table

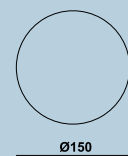
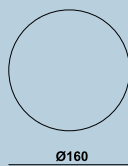
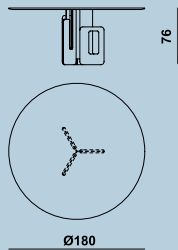

LIAM

Design Maurizio Manzoni



Marble table composed by a shaped marble top 2 cm thick and four marble pedestals. A beautifully designed table featuring a marble top with rounded edges. The smoothness of the edges is echoed in the shape of the pedestals. The four pedestals, simultaneously linear and smooth, combined with the details of the rounded marble base with stainless-steel rim, produce an airy effect. The metal support is part of the design. The table of the image has been realised in Bianco Lilla marble.

Table

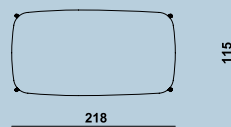
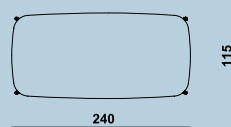
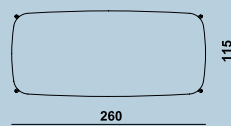
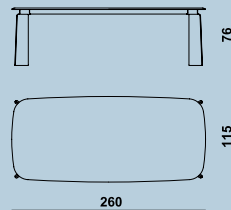

OASI

Design Maurizio Manzoni



Marble table with a cm 2 thick top. The table top has an elegant, rectangular profile and rests on a metal base made up of two elements of different sizes. The contrast between the metal and the empty spaces creates an attractive design that evokes a sense of lightness. Not just a means of support, the metal support under in between the top and base is an essential part of the design. The featured table is made of Kenya Black marble.

Table

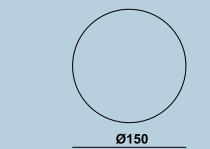
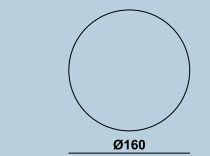
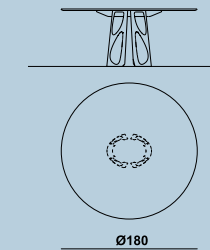
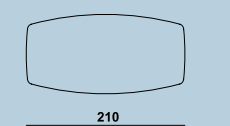
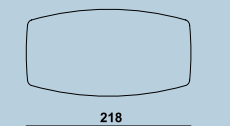
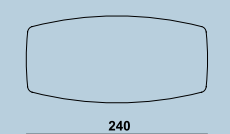
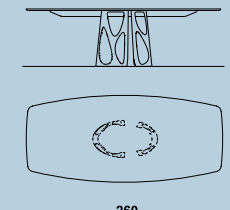

ORION

Design Maurizio Manzoni



Oval marble table top 2 cm thick. A very contemporary oval shape. The pedestal consists of four marble elements, connected by a light metal chrome or lacquered centerpiece.

Table

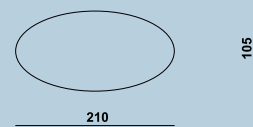
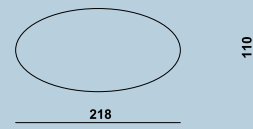
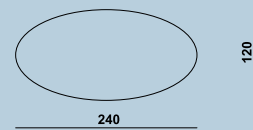
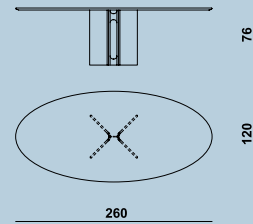

TOHO

Design Maurizio Manzoni



An elegant, round dining table with a clean, simple design in natural materials, Toho can add a sophisticated touch to any contemporary or minimalist home. The Bianco Carrara or Nero Marquinia marble top can include a Lazy Susan as an option. It can also be produced in smoked glass. Three solid marble columns of different diameters, each with metalwork details, make up the pedestal and create an attractive lighting effect due to the varying sizes of the pillars and the placing of the metalwork details.

Table

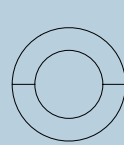
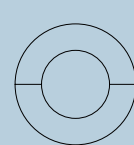
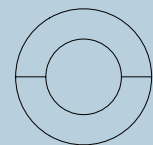
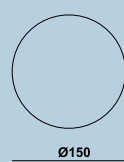
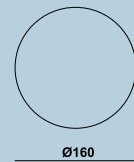
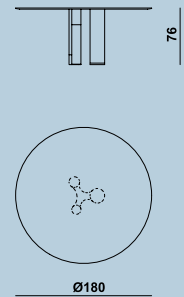

ZEN 2.0

Design Maurizio Manzoni



Zen 2.0. The name of this product reveals the delicate and rich design of this particular table. A design which stimulates the imagination thanks to the experimentation of new and soft shapes. A very particular shape for this magnificent top, important in terms of dimension but softer by the delicate rounded shape of its design. The three rounded pedestals have a unique design, and they are enriched by the combination of natural ash wood and natural marble. The metal frame connects the three pedestals creating an interplay of shapes. Very natural. Very elegant. Simply Zen.

Table

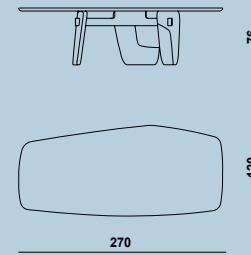

ZEN

Design Maurizio Manzoni



Zen. The name of this product reveals the delicate and rich design of this particular table. A design which stimulates the imagination thanks to the experimentation of new and soft shapes. A very particular shape for this magnificent top, important in terms of dimension but softer by the delicate rounded shape of its design. The top recalls to nature, the use of ash wood presented with its softened forms, recall to the wood crafted by nature over time. The three rounded pedestals have a unique design, and they are enriched by the combination of natural ash wood and natural marble. The metal frame connects the three pedestals creating an interplay of shapes. Very natural. Very elegant. Simply Zen.

Table

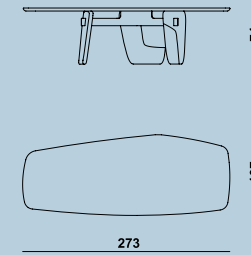

BELT

Design Maurizio Manzoni



Belt. A comfortable chair with a contemporary and fresh design. Upholstered with genuine cowhide leather.

CAMILA

Design Maurizio Manzoni



The clean lines of the Camila chair become elegant also thanks to the back details. The particular shape of the backrest finds the right contrast with the linear and essential line of the metal structure. A perfect combination of modernity and elegance.

IVY SLIM

Design Maurizio Manzoni



Maurizio Manzoni designed the Ivy Slim chair and Ivy armchair with the idea of attaining design and comfort at the same time. The steel structures are upholstered in leather paying the upmost attention to details. The refined topstitching of the leather underlines the high hand-executed ability. The two frontal metal pedestals end with a marble detail which lends a further original feature to the design. The third back pedestal upholstered in leather adds a feeling of lightness and elegance to this unique style.

MOVIE

Design Maurizio Manzoni



The steel structures are upholstered in hard leather. The two frontal metal pedestal ends feature marble detailing.

Chair

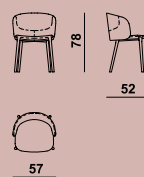

Chair

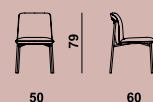

Chair

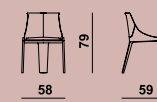

Armchair

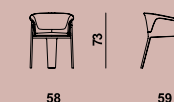

Chair



IVY

Design Maurizio Manzoni



ADON

Design Maurizio Manzoni



Lenzi presents the Adon sofa in two versions: classic and casual. The classic version of the sofa features soft lines, modern but with a more standard version. The sofa can be enriched by marble support in Bianco Carrara or Nero Marquinia in harmony with the sofa feet. The casual version of the sofa is supplied with roller headrests on the rear backrest. Adon is a modular sofa that offers different compositions. Adon. Elegant, with clean lines, modern.

Fabric or leather sofa. Multi-Layer structure, stainless-steel frame profile. Support feet in stainless-steel enriched by Nero Marquinia or Bianco Carrara marble details. Seat cushion with an internal core of polyurethane foam. Overcover in anti-feather canvas. Internal lining: mixture of feather and polyester fibre. Back cushion: Back cushion in down proof fabric padded with foam and polyester fibre.

Sofa

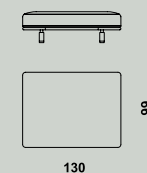
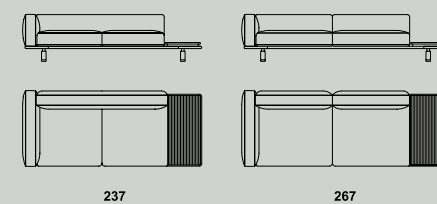
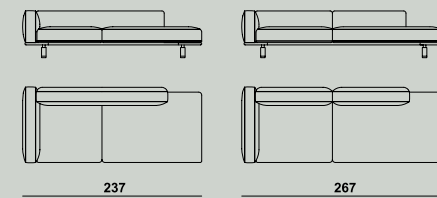
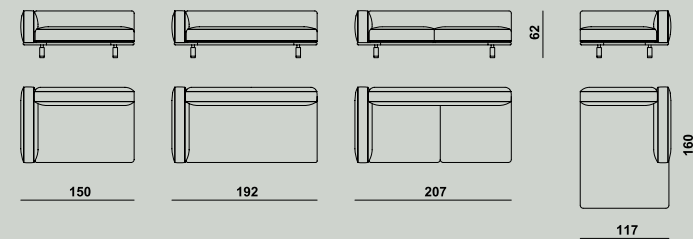
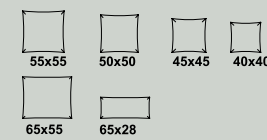
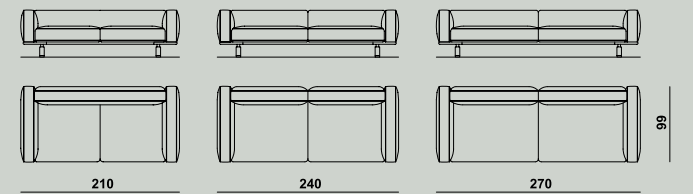

ADON SECTIONAL

Design Maurizio Manzoni



ADON - examples of compositions

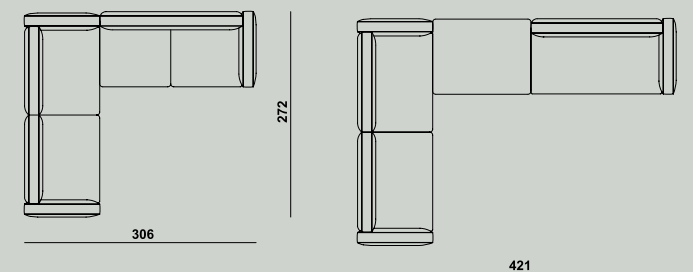
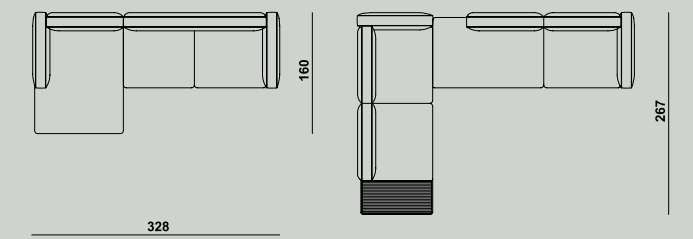

ARIES

Design Maurizio Manzoni



Aries. The sofa that encompasses comfort, style, quality, and a highly original design. Large and comfortable seats accompanied by large and removable back cushions. A very refined stainless-steel structure again here featuring all the components of the sofa: from the feet to the back side of the sofa. The back side of the sofa offers a stunning view: the stainless-steel bar is equipped with metal backrests completely covered in leather and with an adjustable movement. Modern design enriched by shaped marble sides. The shaped form of the marble sides offers soft lines version which allows the perfect blend between the softness of the sofa and the visual hardness of marble. The hardness of the marble is only visual as the armrest is internally lined and padded to give maximum comfort. The marble sides are crossed by a stainless-steel profile. The Aries sofa design has the particularity of being beautiful both from the front and from the back. Perfect for the centre of the room or to separate two spaces.

Sofa

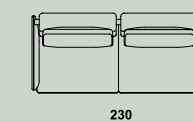
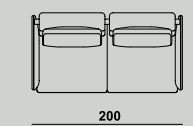
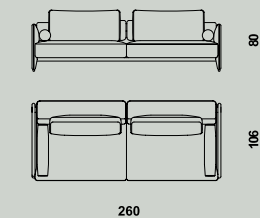

CLAUS

Design Maurizio Manzoni



Claus. Sofa with clean, simple, elegant and very contemporary shapes. The side detail, which can be of the same material as the sofa, can be enriched with the insertion of the marble panel.

CLIFF

Design Maurizio Manzoni



Modern and elegant shape for the Cliff sofa. A wonderful sofa with two large and soft back cushions. The metal structure is a discrete presence on the bottom and rises laterally with harmonic metal lines which end with a wonderful marble element further enriching the original sofa armrest lines.

HUG

Design Maurizio Manzoni



This sofa is not just gorgeous but it's literally a real Hug. The first quality materials used for the padding makes it really comfortable. The design is soft, elegant, and modern at the same time. The backrest and armrest have a design and shape which embrace those enjoying this product. The sofa has been enriched with a marble side detail featuring a metal element.

Sofa

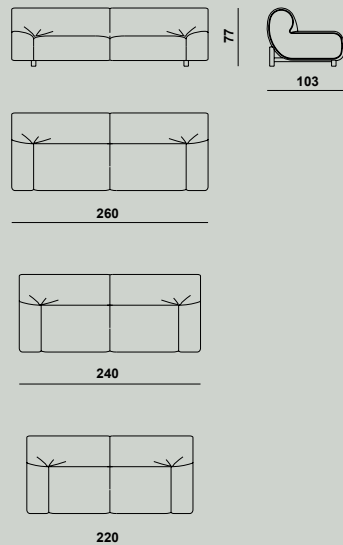

Sofa

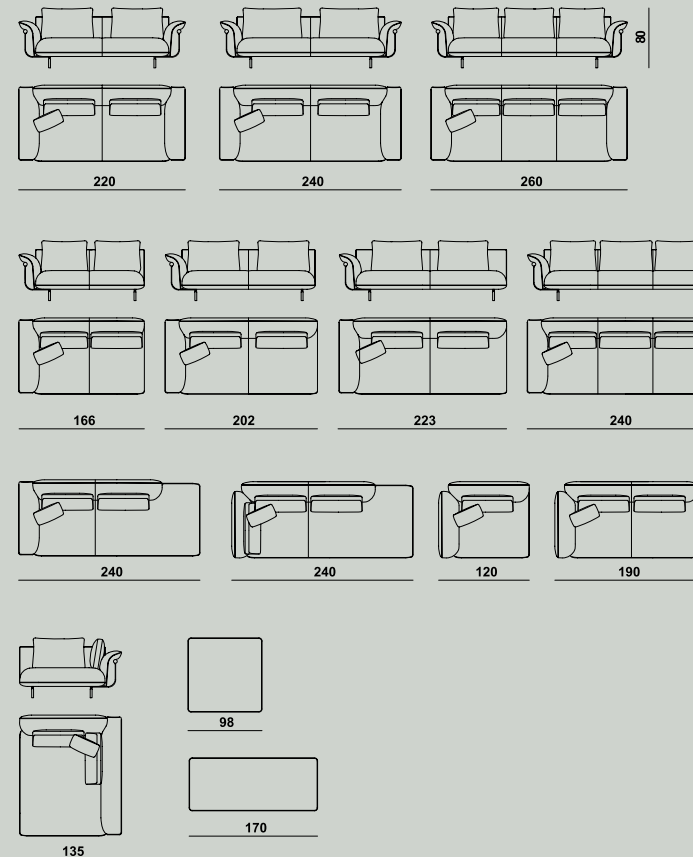

Sofa

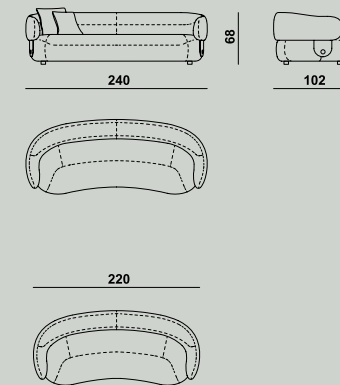

HUG

Design Maurizio Manzoni



Hug armchair. This armchair matches its original and nice design with the maximum comfort. Its swivel base gives the final touch. Padded with top quality materials, the armchair can be realised in fabric, leather or nabuk.

Armchair

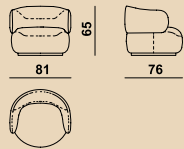

IRIS

Design Maurizio Manzoni



Simple and elegant armchair that can be upholstered in a single material, fabric or leather, or for a bolder design statement a slab of marble can be inserted on the sides. Pedestal with swivel mechanism.

Pouf covered in fabric or leather. An essential element that is always comfortable and a complementary element for relaxing moments.

Armchair

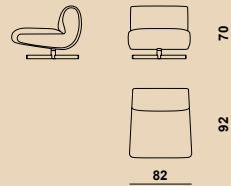

Pouf



MAIA

Design Maurizio Manzoni



Maia armchair is a wonderful piece for any living ambience style. The linear shape of the metal structure finds rich details on the armchair seat and backrest. Maia is a versatile product that can become more delicate by using a monocolour fabric or leather or it may feature more original effects using different material to upholster the armrests.

Armchair

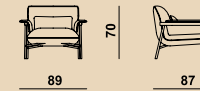

ALDER

Design Maurizio Manzoni



Handmade in sophisticated materials, this splendid sideboard combines practicality and beauty in a sleek design. Made of lacquered wood with four doors, it features interior glass shelves and back and side mirrors, with a stylish marble top. A lacquered metal frame joins the wooden structure to the marble top, echoing the material of the pedestals. The lacquered metal base supports a metal cylinder connected to a solid marble block. The sideboard can be supplied with a smart lighting system.

Sideboard

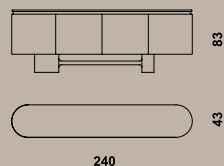

CORE

Design Maurizio Manzoni



Core. A modern and essential buffet featured by its linear and clean shape. Marble sides and bottom details embrace the wooden structure which can be realised in ash wood or lacquered wood. Core is a sideboard that can find the right place in any home of any style.

Sideboard

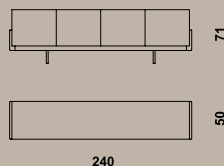

LAYER

Design Maurizio Manzoni



The Layer sideboard with its four doors uses the finest materials to create an architecturally striking piece with a unique design that is perfect for any living room. The total look features a dynamic effect thanks to the use of different materials, at different levels and different tones, offered by the metal, wood and marble. This mixture of three natural components is the very lifeblood of the design: the veneered wooden structure features doors, while the marble top lends a precious feel. The marble side is connected to the main buffet body by a metal detail. The use of marble, invisible Grey in the picture, is played in a way that the final total look lends a feeling of lightness. The internal part of the sideboard is lacquered and complimented by the glass shelves. The inserted marble top is crossed by a marble detail which ends with a metal top. These two tops add dynamism and lightness to the whole piece. The sideboard can be supplied with a smart lighting system.

Sideboard

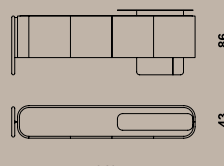

HIRO

Design Maurizio Manzoni



Hiro. Equipped with two doors, which cleverly hide an inner space dedicated to store liquor collections. The finish of the wooden external structure can be lacquered or veneered. This modern bar cabinet makes a majestic statement in any home. The wooden structure is complimented by glass shelves. A metal bar detail placed vertically in the middle of the internal bar recalls and lends continuity to the central marble pillar of the pedestal. The interior features a striking combination of mirror in the back, to enhance depth and brightness. The piece is also complete with one interior drawer for extra storage space. The wooden structure ends with a Nero Marquina or a Bianco Carrara inserted marble top. The pedestal features two solid marble pillars enriched by metal details. The third element is a lacquered metal column. The cabinet can be supplied with a smart lighting system.

Cabinet

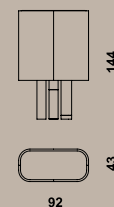

FINN

Design Maurizio Manzoni



Structure in metal and marble top. The Finn mirror is an elegant and contemporary play of marble and mirror elements separated from each other by a delicate and original movement of metal linear details.

ASTER

Design Maurizio Manzoni



Aster sideboard. As per all the Aster range the main peculiarity is the base, composed of a wood cylinder, which can be realised in ash wood or lacquered wood, and a metal structure. The interplay between different materials and shapes creates a particular piece of furniture adding an element of great personality to the environment in which it is placed.

PILOTIS

Design Maurizio Manzoni



Pilotis is a console where marble and metal elements meet to create a modern and harmonious design. 3 metal cylinders that cross and intersect the marble top.

VESTA

Design Maurizio Manzoni



Vesta. A console composed of a top with a particular and fascinating design. Two half moons that never meet but coexist to create an innovative design that decorate the home environment.

Console

Mirror

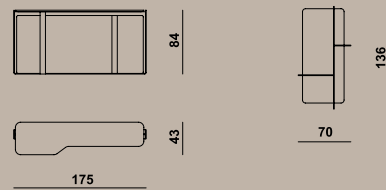

Console

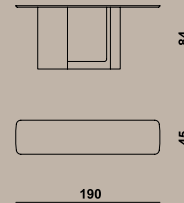

Console

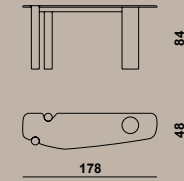

Console

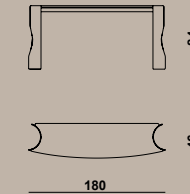

ASTER

Design Maurizio Manzoni



Aster occasional. as per all the Aster range, the main peculiarity is the base, featuring a wood cylinder that can be realised in ash wood or lacquered wood, and a metal structure. The side table is proposed with a lacquered top but can be realised in marble as well. The play of different materials and shapes creates a particular piece of furniture lending great personality to the environment in which it is placed.

CORO

Design Maurizio Manzoni



Coro occasional coffee tables are a perfect mix of linear and delicate effects with metal pedestals and a simple but rich top construction. Natural marble finds the right connection with a lacquered wooden element and by the use of the metal frame which gives geometry and lightness to the top and to the whole total look.

Very nice side table proposed with a metal structure and a marble top. Marble trim also for the base.

EOS

Design Maurizio Manzoni



Solid marble base forged by the hands of expert craftsmen and accompanied by other noble materials, such as wood and glass, creating the perfect living area combination.

GEMINI

Design Maurizio Manzoni



The Gemini coffee table top can be made in Nero Marquina or Bianco Carrara marble. The top can also be realised in smoked glass which allows enjoying the view of the details which enriched the pedestals and the metal parts. Pedestals feature two marble pillars of different diameters and a third cylindrical metal element. The three basement columns are joined together at the bottom, creating an internal trim, and on the upper side, visible with the glass top.

Side table realised with a smoked glass top. The pedestals consist of a marble pillar which starts and ends with defined metal parts.

Coffee table

Occasional table

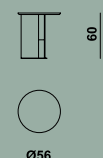
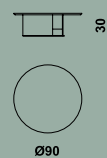

Coffee table

Occasional table

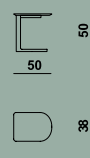
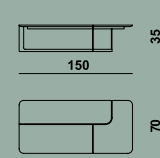
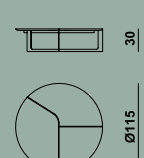

Coffee table

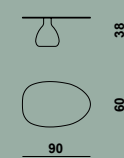
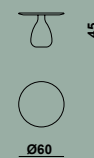

Coffee table

Occasional table

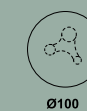
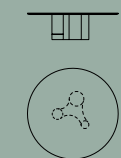

GLOW

Design Maurizio Manzoni



Occasional range composed by three elements in different sizes. The coffee tops can be both in marble or smoked glass, while for the side table the top can be in marble only. Metal structure for the base enriched with marble top on bottom. The base structure can be lacquered or chromed.

NEBULA

Design Maurizio Manzoni



Nebula: Clouds. Two raindrops. The shape of these tops is reminiscent of raindrops, water, sea-worn rocks. A rounded shape lends a soft effect to the marble. A coffee table set consisting of shaped marble tops and a metal structure for the base. The metal cylinder of the base runs through the marble until it is clearly visible on the surface of the top.

Coffee table

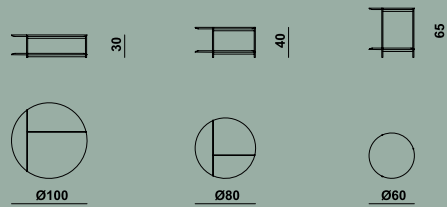

Coffee table

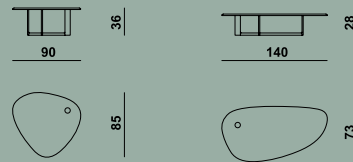

LOTO

Design Maurizio Manzoni



Variations in heights and different materials that come together as a whole to make the atmosphere of the house welcoming and elegant.

Wall lamp



Table lamp



Floor lamp

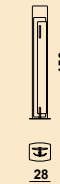

SOLARE

Design Maurizio Manzoni



Lighting collection with light playing with smoked glass and translucent marble elements. Solare. A collection including a table lamp, chandelier, floor lamp and wall lamp with round elements in metal, marble and glass intersecting one another giving a smooth light to the environment of the living room.

Wall lamp



Table lamp



Floor lamp

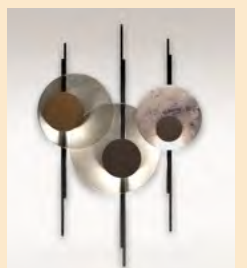
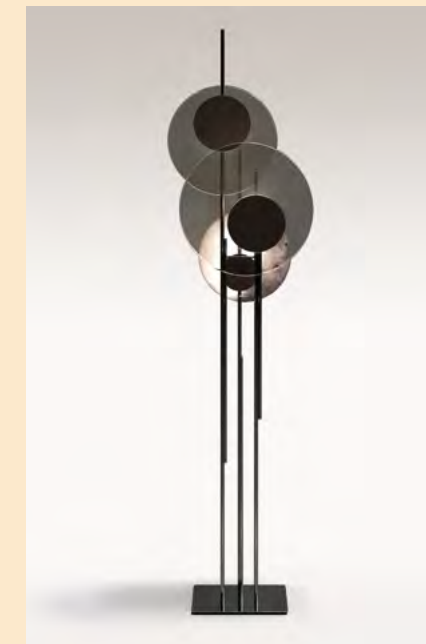
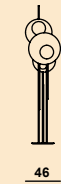

STILETTO

Design Maurizio Manzoni



Lighting collection with light playing with translucent marble elements at different heights. Stiletto. A collection including a table lamp, chandelier, floor lamp and wall lamp with marble blocks intersecting one another playing with the different heights giving a smooth light to the environment of the living room.

MOON

Design Maurizio Manzoni



A round shape for the Moon mirror. Mirror and marble elements have painstakingly crafted and merged together. The linear and semicircular metal frame gives the perfect effect to this gorgeous wall mirror.

ELIO

Design Maurizio Manzoni

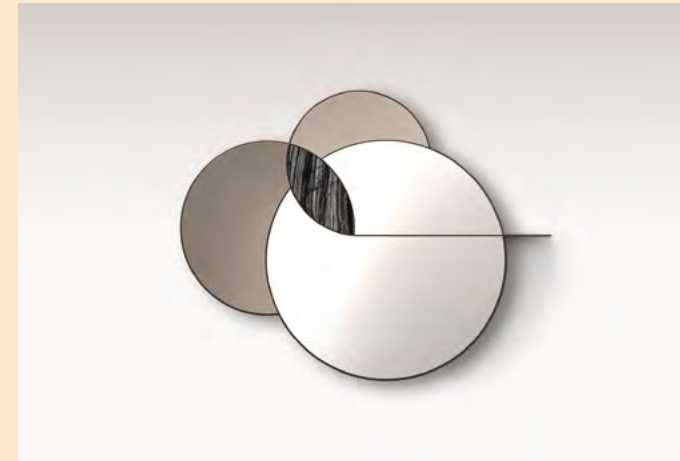

A perfect game of different materials joined together by a wonderful marble element and an original metal frame. Elio is not only a mirror but a piece of decoration for your wall.

Table lamp

Floor lamp



45



30



170



22

Mirror



118



80



78

Mirror

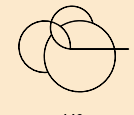

146





C

LENZI
HOME COLLECTION

CONCEPT AND GRAPHIC DESIGN

Cortez Design House

AD

Maurizio Manzoni

PHOTOGRAPHER

Gio Sormani

STYLING

Veronica Leali

THANKS TO

Aponte Boretti
Carpet Edition
ccontinua + mamt
Cuore Carpenito
Claire Lune Ceramics
Elena Meneghini
Kasthall
Firmamento Milano
Fontanaarte
Gaetano di Gregorio
Lavinia Fantappiè
Mamate
Rito Collection
Tooy
Unurgent Argilla
Xio Ceramics

SPECIAL THANKS TO

Figaia Cave S.p.A Luni (SP)
F.T.Cave S.r.L – Carrara
3T di Tognini Nicola
Paolo dell'Amico
Teatro del Silenzio Lajatico (Pisa)

LENZI is a registered trademark of
Valdera Export Srl
via Collodi, 12 La Capannina
56035 Casciana Terme Lari (Pisa) ITALY
ph +39 0587 685100
mail info@lenzihome.com
lenzihome.com

